



Pump Division



**Type: PLEUGER - STANDARD
SUBMERSIBLE MOTOR PUMPS**

USER INSTRUCTIONS.

INSTALLATION, OPERATION, MAINTENANCE

PCN =71569293 01-06 (G)

(incorporating 1042.277/7)



These instructions must be read prior to installing, operating, using and maintaining this equipment

CONTENTS

	PAGE		PAGE
1 INTRODUCTION AND SAFETY	4	6 MOTOR FILLING.....	17
1.1 General.....	4	6.1 Antifreeze	17
1.2 CE- marking and approvals.....	4	6.2 Type of use.....	17
1.3 Disclaimer.....	4	6.3 Filling quantities	18
1.4 Copyright	4	6.4 Accessories and hardware for filling and topping up.....	18
1.5 Duty conditions.....	4	6.5 General information about filling	18
1.6 Safety	5	6.6 Filling instructions.....	19
2 TRANSPORT AND STORAGE	5	7 COMMISSIONING, START-UP AND SHUTDOWN.....	29
2.1 Consignment receipt and unpacking.....	5	7.1 Commissioning.....	29
2.2 Handling and lifting.....	6	7.2 Operation.....	29
2.3 Storage.....	6	7.3 Switching off the unit.....	30
2.4 Recycling and end of product life	7	8 MAINTENANCE	30
3 DESCRIPTION.....	7	8.1 General information.....	30
3.1 Technical data	7	8.2 Pump units	30
3.2 Delivery contents	7	8.3 Measuring insulation	30
3.3 General data.....	7	8.4 Removal of the pump unit	32
3.4 General description	7	8.5 Overhaul of the pump unit.....	32
3.5 Submersible motor	8	10 CERTIFICATION	35
3.6 Pump and check valve	10		
4 INSTALLATION.....	10		
4.1 Hydraulic installation	10		
4.2 General advice for installation.....	10		
4.3 Flexible hose riser pipe	10		
4.4 Centralisers	11		
4.5 Checks before installation	11		
4.6 Installation of pre-assembled pump units	11		
4.7 Riser pipes with flange connections.....	11		
4.8 Riser pipe with pipe socket.....	12		
4.9 Assembly of submersible motor pumps before installation	12		
5 ELECTRICAL CONNECTION	12		
5.1 Motor	12		
5.2 Protective measures against shock-hazard voltage.....	13		
5.3 Motor protection	13		
5.4 Short circuit protection.....	13		
5.5 Motor connection diagrams.....	14		
5.6 Adjustments for soft-starter and soft stop devices	16		
5.7 Operation of submersible motors with static frequency converter.....	16		
5.8 Resistance sensor PT100 (RTD)	17		

1 INTRODUCTION AND SAFETY

1.1 General



These Instructions must always be kept close to the product's operating location or directly with the product.

Flowserve products are designed, developed and manufactured with state-of-the-art technologies in modern facilities. The unit is produced with great care and commitment to continuous quality control, utilising sophisticated quality techniques, and safety requirements.

Flowserve is committed to continuous quality improvement and being at service for any further information about the product in its installation and operation or about its support products, repair and diagnostic services.

These instructions are intended to facilitate familiarization with the product and its permitted use. Operating the product in compliance with these instructions is important to help ensure reliability in service and avoid risks. The instructions may not take into account local regulations; ensure such regulations are observed by all, including those installing the product. Always coordinate repair activity with operations personnel, and follow all plant safety requirements and applicable safety and health laws and regulations.



These instructions should be read prior to installing, operating, using and maintaining the equipment in any region worldwide. The equipment must not be put into service until all the conditions relating to safety, noted in the instructions, have been met.

1.2 CE- marking and approvals

It is a legal requirement that machinery and equipment put into service within certain regions of the world shall conform with the applicable CE Marking Directives covering Machinery and, where applicable, Low Voltage Equipment, Electromagnetic Compatibility (EMC), Pressure Equipment Directive (PED) and Equipment for Potentially Explosive Atmospheres (ATEX).

Where applicable, the Directives and any additional Approvals, cover important safety aspects relating to machinery and equipment and the satisfactory provision of technical documents and safety instructions.

Where applicable this document incorporates information relevant to these Directives and Approvals. To confirm the Approvals applying and if the product is CE marked, check the serial number plate markings and the Certification, see section 10 **CERTIFICATION**.

1.3 Disclaimer

Information in these User Instructions is believed to be reliable. In spite of all the efforts of Flowserve Pump Division to provide sound and all necessary information the content of this manual may appear insufficient and is not guaranteed by Flowserve as to its completeness or accuracy.

Flowserve manufactures products to exacting International Quality Management System Standards as certified and audited by external Quality Assurance organisations. Genuine parts and accessories have been designed, tested and incorporated into the products to help ensure continued product quality and performance in use. As Flowserve cannot test parts and accessories sourced from other vendors the incorrect incorporation of such parts and accessories may adversely affect the performance and safety features of the products. The failure to properly select, install or use authorised Flowserve parts and accessories is considered to be misuse. Damage or failure caused by misuse is not covered by the Flowserve warranty. In addition, any modification of Flowserve products or removal of original components may impair the safety of these products in their use.

The operational safety of the delivered unit is only guaranteed for use according to the limitations described in section 3.1, *Technical data*. The limits given in the data sheet may not be exceeded.

1.4 Copyright

All rights reserved. No part of these instructions may be reproduced, stored in a retrieval system or transmitted in any form or by any means without prior permission of Flowserve Pump Division.

1.5 Duty conditions

This product has been selected to meet the specifications of your purchaser order. The acknowledgement of these conditions has been sent separately to the Purchaser. A copy should be kept with these instructions.



The product must not be operated beyond the parameters specified for the application. If there is any doubt as to the suitability of the product for the application intended, contact Flowserve for advice, quoting the serial number.

If the conditions of service on your purchase order are going to be changed (for example liquid pumped, temperature or duty) it is requested that the user seeks the written agreement of Flowserve before start up.

1.6 Safety

1.6.1 Summary of safety markings

These User Instructions contain specific safety markings where non-observance of an instruction would cause hazards. The specific safety markings are:

 **DANGER** *This symbol indicates electrical safety instructions where non-compliance will involve a high risk to personal safety or the loss of life.*

 *This symbol indicates safety instructions where non-compliance would affect personal safety and could result in loss of life.*

 *This symbol indicates "hazardous and toxic fluid" safety instructions where non-compliance would affect personal safety and could result in loss of life.*

 *This symbol indicates safety instructions where non-compliance will involve some risk to safe operation and personal safety and would damage the equipment or property.*

Note: *This sign is not a safety symbol but indicates an important instruction in the assembly process.*

1.6.2 Personnel qualification and training

All personnel involved in the operation, installation, inspection and maintenance of the unit must be qualified to carry out the work involved. If the personnel in question do not already possess the necessary knowledge and skill, appropriate training and instruction must be provided. If required the operator may commission the manufacturer/supplier to provide applicable training.

Always coordinate repair activity with operations and health and safety personnel, and follow all plant safety requirements and applicable safety and health laws and regulations.

1.6.3 Safety action

This is a summary of conditions and actions to help prevent injury to personnel and damage to the environment and to equipment.

 **DANGER** *Before maintenance and repair work is started the motor of the pump unit must first be completely isolated from the electrical power supply.*

Work on the unit can only be performed when it is isolated and locked off.

The procedures for stopping the unit in these User Instructions must be strictly followed.

 **DANGER** *Danger from electricity must be eliminated (for details see, for example, the regulations of the VDE and local power supply companies).*

 *In addition to the safety instructions covered in the main Safety section also note any special safety instructions mentioned in all other sections, e.g. for private use.*

 *Before restarting, the instructions listed in section 7, COMMISSIONING, START-UP AND SHUTDOWN, must be followed.*

 *Information placed directly on the unit must be strictly observed, for example:*

- Labelling of connections
- Rating plate

Units conveying hazardous substances must be decontaminated.

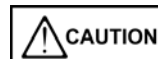
 *The unit may only operated in a fully assembled condition and with the pump completely filled and immersed.*

Non-compliance may result in the following:

- Failure of important unit functions
- Failure of stipulated methods of maintenance and repair
- Risks to personnel from electrical, mechanical or chemical effects
- Danger to the environment by leakage during production of dangerous media

2 TRANSPORT AND STORAGE

2.1 Consignment receipt and unpacking

Submersible pumps are subjected to a thorough inspection before leaving the factory and are supplied with operating instructions for fitting, starting, care etc, that conform to international safety regulations.

Immediately after receipt of the equipment it must be checked against the delivery and shipping documents for its completeness and that there has been no damage in transportation. Any shortage and or damage must be reported immediately to Flowserve Pump Division and must be received in writing within one month of receipt of the equipment. Later claims cannot be accepted.

Check any crates, boxes and wrappings for any accessories or spare parts that may be packed separately with the equipment or attached to side walls of the box or equipment.

Each product has a unique serial number. Check that this number corresponds with that advised and always quote this number in correspondence as

well as when ordering spare parts or further accessories.

2.2 Handling and lifting



Take special care when handling the pump unit. Make certain that it does not hit against walls, steel structures or floors etc.

Overlong pump units must be handled according to the following section.

2.2.1 Erection of long units



For transport, ensure that the hoist has an adequate carrying capacity.



Units less than 1 000 kg (2 200 lb.) do not carry any weight information.

Units that are delivered or stored in several sub-assemblies due to extreme length must be assembled during installation into the well. Special fitting instructions must be requested from the manufacturer for this.

A unit that is shipped on a transport rail due to its extreme length must be lifted into the vertical position on this rail (i.e. an auxiliary carrier) before fitting into the well.



Due to the danger of sagging, pump units that exceed the permissible length must be supported by an auxiliary carrier (U or H carrier) when lifted into the vertical position. This carrier may only be removed after the pump unit is hanging vertically from the crane or lifting block. (See Figure 2-1.)

When assessing the diameter of the unit, use the smaller size from the pump and motor. This can be found on the rating plate or the data sheet.

Table 2-1

Rated diameter	Permissible length
6 in. (152 mm)	3,3 m (10.8 ft)
8 in. (203 mm)	3,5 m (11.5 ft)
10 in. (254 mm)	4,4 m (14.4 ft)
12 in. (305 mm)	4,7 m (15.4 ft)



Under no circumstances must the power cables be used for lifting or moving the motor.

Figure 2-1

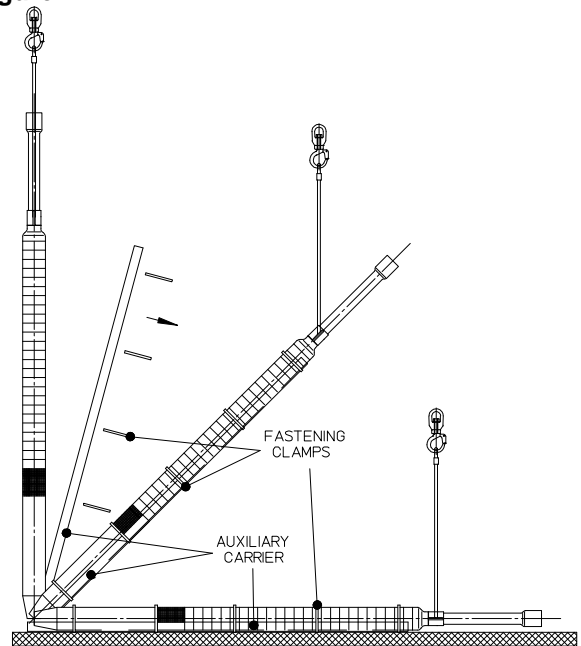

2.3 Storage



Store the pump unit vertically in a dry, well ventilated location. If it cannot be foreseen when the unit will be installed, the following instructions must be followed.

2.3.1 General remarks



Submersible pump units need special storage conditions. For functional reasons some inner parts (e.g. the stator and rotor plates) cannot be produced from corrosion-resistant materials and are therefore sensitive to any type of air humidity.

All units may basically be stored either in a filled or unfilled condition; however these two types of storage require different treatment of the unit.



All units must be stored vertically, secured appropriately in this position to prevent tipping over.



The leads of the power cables must be protected from moisture. Ensure that the power cables and, if applicable, the signal cables are not bent during storage.

2.3.2 Requirements for the storage area

- a) The storage area must be well ventilated.
- b) Air humidity should be in a range of 40 to 60%.
- c) Temperatures:
 - +50 to -25 °C (+122 to -13 °F) for units with unfilled motors
 - +50 to 0 °C (+122 to +32 °F) for units with MX type motors (water-filled without anti-freeze)
 - +50 to -15 °C (+122 °F to +5 °F) for units with motors originally filled by the manufacturer
- d) For temperatures down to -15°C, (+5 °F) see the guidelines in the instructions for filling submersible pump motors in section 6.1, *Antifreeze*.

2.3.3 Storing for up to four weeks

No special arrangements are required.

2.3.4 Storing between one and 24 month

For storage between one and 24 months, it is recommended that the shaft of the unit be turned at intervals of approximately 8 weeks. For this it may be necessary to remove a mounted pressure housing, including the check valve. On pump units where this is not possible, the pump and motor must be separated.

If needed, separate instructions should be requested from the manufacturer.

2.3.5 Storing for over 24 month



If the pump unit is stored for more than 24 months a complete visual inspection at the Flowserve manufacturing plant is recommended. An authorised Flowserve factory representative can also carry out this inspection.

2.4 Recycling and end of product life

At the end of the service life of the product or its parts, the relevant materials and parts should be recycled or disposed of using an environmentally acceptable method and local regulations. If the product contains substances that are harmful to the environment, these should be removed and disposed of in accordance with current regulations. This also includes the liquids and or gases in the "seal system" or other utilities.



Make sure that hazardous substances are disposed of safely and that the correct personal protective equipment is used. The safety specifications must be in accordance with the current regulations at all times.

3 DESCRIPTION

3.1 Technical data

Each unit is individually manufactured to the special requirements of the customer. The specific technical data regarding head, delivery rate, current requirement, minimum permissible flow velocity on the external motor surfaces etc can be found in the data sheet delivered with the unit or in the order confirmation.

3.2 Delivery contents

- Pump unit
- These User Instructions
- Technical data sheet

3.3 General data

3.3.1 Normal operating conditions

- Temperature: see data sheet
- Sand content: max. 25 mg/l (0.03 oz/fl.oz.)
- Water velocity along motor surface: see data sheet
- No impurities that could lead to deposits and blockages within the pump or to deposits on the motor surface
- No water hammer
- Maximum 3 minutes operation against closed slide valve
- Operation within prescribed voltage tolerances
- Permissible operational range: 50 to 120 % of the best efficiency point (BEP)
- Correctly selected and adjusted motor protection
- Observation of the maximum permissible starting frequency



If other working conditions are required please contact Flowserve for advice.



At higher ambient temperatures and/or lower flow velocities on the external motor surfaces, or if there is risk of clogging, special measures for heat dissipation are required. This must be checked with the manufacturer by indicating the ambient conditions. In this case, the suitability of the unit for its planned application must be confirmed by the manufacturer.

3.4 General description

Submersible motor pumps are subjected to a thorough inspection before leaving the factory and are supplied with operating instructions for fitting, starting and care that conform to general safety regulations.

Standard submersible motor pumps are used to transport cold clean water under normal operating conditions.

The Pleuger submersible motor pump has been developed for installation in wells and as a result has a distinctive slim design. The Pleuger submersible motor pump, because of its various features, can also be used for other applications with different design modifications.

The submersible motor pump consists of a submersible motor, a submersible pump and usually a check valve. The complete pump unit is freely suspended on the rising main, which is supported at the wellhead.

Other uses or applications must be agreed by the manufacturer.

Power cables and, if applicable, signal cables are fixed to the riser pipes by means of cable clips.

The ideal construction of a water supply system is shown in Figure 3-1. Since this shows a basic arrangement, the actual layout must be adapted to local and technical conditions.

The additional listed components are recommendations for operational safety and the protection of the pump unit.

Figure 3-1
Water supply system

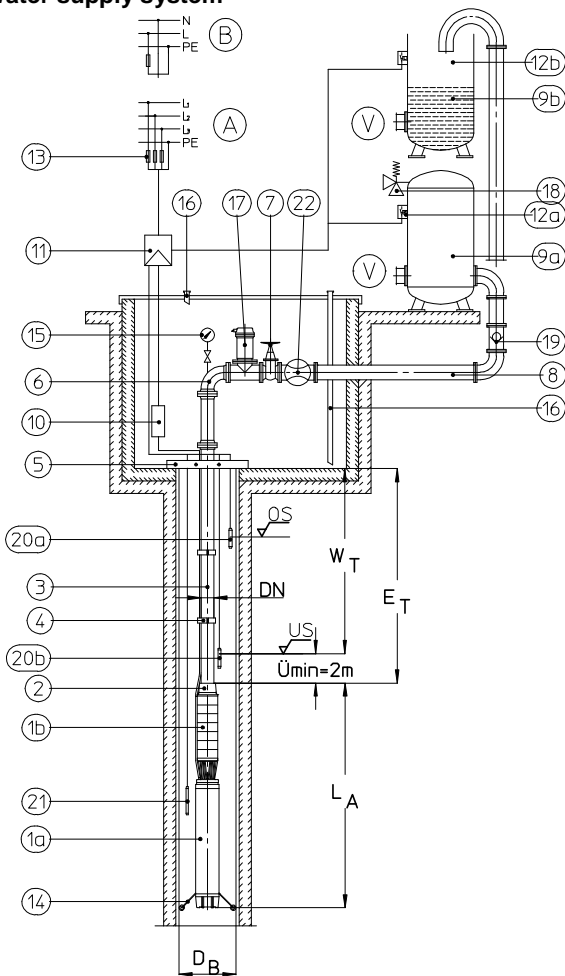

Ref.	Description
1a	Submersible motor
1b	Submersible pump
2	Check valve
3	Riser pipe
4	Cable clips
5	Support clamp
6	Elbow
7	Control valve
8	Delivery pipe
9a	Pressure vessel
9b	High level tank
10	Terminal box for power cable
11	Switchgear or switchboard
12a	Pressure switch
12b	Float switch
13	System fuses
14	Centering device
15	Pressure gauge
16	Well shaft vents
17	Double orifice air valve
18	Safety valve
19	Check valve (optional)

For safe operation, the following are also recommended:

20a	Water level detector, upper
20b	Water level detector, lower
21	Pressure sensor for water level measuring system
22	Flowmeter

Explanations and abbreviations:

- DB Well diameter
- ET Installation depth
- LA Unit length incl. check valve
- US Lower operating level = dry running protection
- OS Upper operating level (only for automatic operation)
- Ü Minimum water level above pump outlet
- V To the consuming device
- WT Minimum (dynamic) water level (depending on NPSH)
- A Connection for a three-phase motor
- B Connection for a single-phase motor

3.5 Submersible motor

The so-called “wet” electric motor is a water-filled three-phase AC squirrel-cage motor with a water-tight winding, which is operating in water and is designed especially for direct drive of submersible pumps. The motor filling-water cools the winding and bearings as well as lubricating the thrust and radial bearings.

The submersible-motor-pump is connected to the lower end of a riser pipe and submerged in the pumped medium. The power supply is through water resistant power cables fastened to the riser pipes with cable clips.

For operation the motor must be filled with potable water. Antifreeze can be added to the potable water if there is a risk of freezing. As the motor is hermetically sealed and equipped with a pressure/volume compensating device the motor filling remains in the motor for the duration of operation.

On motors larger than 10 in. (254 mm) an impeller fitted on the motor shaft provides an internal water circuit for better cooling.

When the unit is operating, the motor filling-water becomes warm and increases in volume. Excess water is released through a vent valve/pressure relief valve located at the top of the motor. After the unit is switched off, the filling-water cools down and the volume decreases. A breather diaphragm compensates for the lower pressure resulting from the decrease in volume. This arrangement avoids under-pressure in the motor and the ingress of pumped medium. The change of volume by varying temperatures continues over the entire lifetime of the pump unit.

Although the motor filling-water and the pumped liquid surrounding the motor will mix if there is leakage from the seals, the motor remains operative due to its water-lubricated journal bearings.

At lower installation depth the motor can, on customer request, be equipped with a header tank connected to the motor with a filling and venting pipeline instead of a pressure compensating system.

Basically, "wet" motors operate maintenance-free with the ammeter acting as a monitoring device.

The internal temperature of the motor can be monitored with one or two additional temperature sensors mounted inside the end coils of the motor winding. These sensors can trigger a high temperature warning signal or switch off the motor.

3.5.1 Stator winding

The stator winding consists of winding wire provided with special insulation.

The power cables are connected to the winding by a special watertight splice and leave the motor through stuffing boxes.

The winding and cable connections are tested at high voltage according VDE 0530 IEC60034-1 immersed in water, at twice the operating voltage plus 1 000 volts, or a minimum of 2 000 volts.

3.5.2 Rotor

The rotor winding consists of induction welded copper bars with short-circuit rings. The rotors are dynamically balanced and are protected against corrosion by a protective varnish. The drive shaft end is made of stainless steel.

3.5.3 Bearings

The "Michel type" axial thrust bearing is located in the motor base and is designed to handle very high thrust loads; they are dimensioned so that they can support the axial thrust of the pump's rotating assembly as well as all hydraulic loads.

The thrust bearing is bi-directional.

A fixed counter-thrust bearing is also provided.

The journal bearings are slide bearings.

The motor filling liquid lubricates the journals and thrust bearings.

3.5.4 Mechanical seal

The motor is equipped with a single directional operating mechanical seal, which can operate in both directions of rotation.

3.5.5 Starting procedures

The motors can have different operating modes and starting procedures. Essentially, these are:

- Direct-on-line (DOL)
- Star-delta starting
- Starting via an auto-transformer
- Starting via soft-starter. (See also section 3.5.6, *Starting via soft-starter*)
- Static-frequency converter operating. (See also section 3.5.7, *Static-frequency converter operating with submersible motors*)
- Single-phase motor - refer to Flowserve.

For direct-on-line (DOL), Star-delta starting and starting via an auto-transformer only the particular starting procedures, the electrical data and the connection diagram for the motor and the operating data for the motor have to be followed. These are marked in the technical data sheet.

For all other operating modes special procedures have to be followed that are described in detail below.

3.5.6 Starting via soft-starter

Pleuger submersible motors can be operated via "soft-start and soft-stop devices". These instructions relate to radial and mixed flow pumps.

Axial flow pumps must be referred to the manufacturer on an individual basis.

A compensation-capacitor must not be installed at the junction between soft-start and soft-stop devices and the motor.

Power output reduction is not necessary if the conditions in section 5.6, *Adjustments for soft-starter and soft stop devices*, are observed.

Soft-start ramp up and soft-stop ramp down times must be clarified with the manufacturer after the hydraulic system data is finalised.

3.5.7 Static-frequency converter operating with submersible motors

Technical data needs to be taken from the specific data sheet.

For submersible motors that are later converted to static-frequency converter operation, the required data must be requested from the manufacturer.

3.5.8 Direction of rotation

The direction of rotation depends on the pump type. Reversing two phases of the power supply will change the direction of rotation of all three-phase squirrel-cage motors; changing the direction of rotation of a single-phase motor is not possible.

3.5.9 Resistance thermometer PT100 (RTD)

Either one or two temperature sensors PT100 (RTD) are installed with pressure and watertight connections to a signal cable. As the temperature sensors are mounted on the winding head they can only be removed after dismantling the motor.

3.6 Pump and check valve

Radial or semi-axial centrifugal pumps are used as single or multistage pumps. The pump stages of pump types NB6 and NB8 are bolted together with tie-bolts. The pump bowls of all other types of pumps are bolted together one by one.

The dynamically balanced impellers are fixed to the pump shaft by means of keys. The pump shaft runs in journal bearings that are lubricated by the pumped medium.

Power transmission for 6 in. (152 mm) and 8 in. (203 mm) motors is via a spline coupling; on all other motors a keyed coupling is used.

The check valve of pump types NB6 and NB8 is an integral part of the pump. On all other pump types the check valve is an independent part, mounted onto the discharge casing of the pump.

4 INSTALLATION

4.1 Hydraulic installation

A typical design for a water supply system is shown in Figure 3-1, *Water supply system*. As this shows a basic arrangement, the actual layout must be adapted to local conditions. (The additional components listed are recommendations for operational safety and protection of the pump unit.)

4.2 General advice for installation

The following criteria must be taken into account to determine the installation position and depth:

- Vertical installation in the well above the filter line, so that an adequate motor cooling flow is guaranteed along the external motor surface
- Sufficient water cover
- Static water level at least 2 m (6.6 ft.) above the pump outlet
- A dynamic water level above the suction housing, taking into account the required NPSH for the pump. (See pump characteristic curve.)
- Flow rate. (See pump characteristic curve.)
- Supply conditions of the pumping medium (depends on the installation conditions)

 **Regardless of the above, the pump unit should be installed above the well screen whenever possible, to avoid foreign matter being drawn directly into the pump inlet, and also to ensure that there is sufficient water flowing across the motor to assist heat transfer. If**

this is not possible a flow shroud should be provided to induce the flow of water over the motor.

 ***Pump units can only be operated with a completely filled and immersed motor. The liquid level of the motor must always be checked before installation, and if necessary adjusted according to the information on the data card supplied with the motor.***

4.3 Flexible hose riser pipe

 ***If a flexible hose is used instead of steel pipes, these will twist against the direction of rotation of the motor when it is switched on, depending on the locked rotor torque of the motor. In this case, the power cable (and, if provided, the signal cable) fastened to the riser hose would also twist and tighten. To prevent the cables being pulled out of their junction boxes, they should not be laid parallel to the riser hose but wound around it in the opposite direction to the rotation of the motor. The number of turns required will depend on the length and stiffness of the riser hose line and the locked rotor torque of the motor. The exact operating characteristics will need to be requested from the hose manufacturer.***

4.4 Centralisers

When pump units are installed in narrow wells the risers, whether steel pipes or hose lines, will need to be centralised to prevent them from touching the wall of the well which could cause damage to any cables fastened to them.

4.5 Checks before installation

⚠ Before beginning installation, check the dependability of auxiliary equipment, particularly hoists, as well as comparing the information on the data sheet with that on the rating plate on the motor.

Ensure that the line voltage (measured between two phases) is equal to the motor voltage shown on the rating plate.

The maximum permissible voltage fluctuation can be seen in the data sheet. Greater voltage and frequency fluctuations must be stated in the order and confirmed by the factory. In case of doubt, contact Flowserve or the nearest factory representative before starting up the unit.

Before installing, the insulating resistance of the motor must be measured as shown in section 8.3, *Measuring insulation*.

Ensured that the well diameter is large enough down to the installation depth, so that the pump unit can be installed without difficulties. If the riser connections are made of pipes with flanges, these must have cut outs for the cable if the well diameter is narrow.

When lowering the unit, ensure the power cable is neither squeezed nor scraped. To protect the power cables, we recommend that the well head is lined with a rubber sheet at the entry point of the power/signal cable into the well pipe and it is fed into the well shaft using a cable roller. (Figure 4-1)

During lowering, the unit must always hang freely and must not become wedged in the well shaft. Always ensure that the pump can be rotated freely. If needed, attach a cable clip every 3 m (approx 10 ft.) of pipe length.

For especially narrow and deep wells, the insulating measurements shown in section 8.3, *Measuring insulation*, should be repeated to determine possible damage to the power cables in time.

Figure 4-1
"A"
"B"

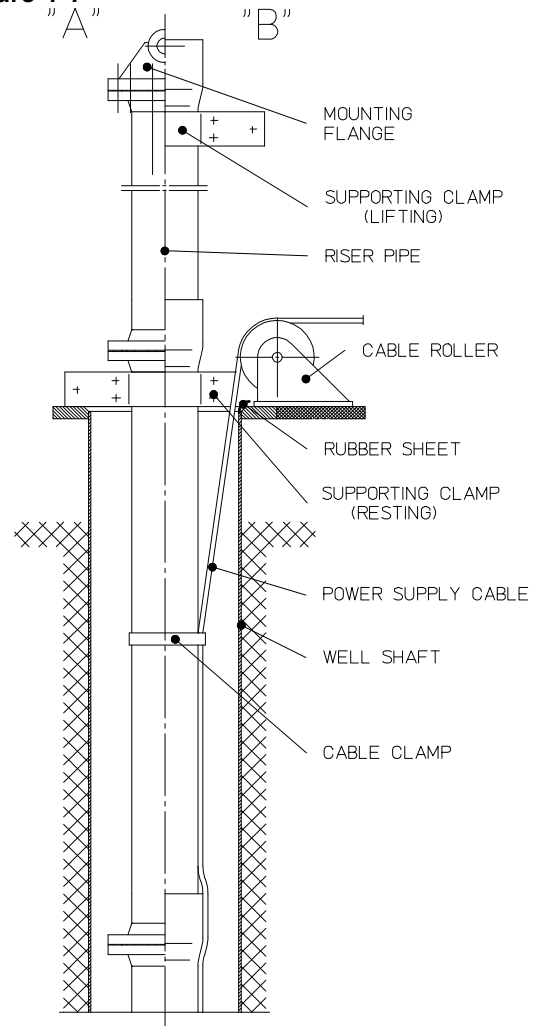

4.6 Installation of pre-assembled pump units

Mount the first length of pipe, which should not be longer than 1 m (39 in.), onto the assembled pump unit.

Fasten the power cables, control lines and instrument leads (if any) with cable clips onto the pipe.

4.7 Riser pipes with flange connections (Reference "A" in Figure 4-1)

- Mount a "lifting dolly" to the riser pipe flange, and hang the complete unit on a suitable hoist.
- Lower the pump unit into the well, allowing sufficient pipe to protrude above the well to enable the installation clamp to be mounted onto the riser pipe.
- Continue to lower the unit until the installation clamp rests on the well rim flange.
- Remove the lifting dolly, and attach it to the next riser pipe to be installed.
- Fasten the power cable, control lines and instrument leads (if any) with cable clips to the riser pipe.

- f) Lift the next pipe to be installed into a vertical position and bolt it to the pipe resting on the well rim flange.
- g) When this has been completed lift the unit sufficiently to enable the supporting clamp to be removed.



Do not allow the pipe to be lowered or to slip whilst carrying out this operation. This could result in damage to hands and in extreme cases loss of fingers.

- h) Install the remaining riser pipes as described from point b) to e).
- i) Finally mount the wellhead support plate onto the last length of riser pipe. Feed the power cables and, if necessary, the control lines and/or instrument leads through the corresponding holes in the wellhead support plate and connect them to the junction box or control panel.

4.8 Riser pipe with pipe socket

(Reference "B" in Figure 4-1)

- a) Connect a lifting clamp underneath the pipe socket of the screwed riser pipe and lift the complete pump unit with a suitable hoist.
- b) Lower the pump unit into the well as far as the installation clamp mounted underneath the socket of the riser pipe.
- c) Lower the unit and rest it on the well rim flange.

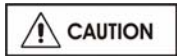

Do not let the pump unit slip through the installation clamp.

- d) Remove the lifting clamp and attach it to the next riser pipe and connect this to the pipe already installed.
- e) Fasten the power cables and, if necessary, the control lines and/or instrument leads with cable clips onto the riser pipe.
- f) Lift the unit and remove the resting supporting clamp.
- g) Install the remaining riser pipes as described from point b) to f).
- h) Finally mount the wellhead support plate onto the last riser pipe. Feed the power cables and, if necessary, the control lines and/or instrument leads through the corresponding holes in the wellhead support plate and connect them to the junction box or control panel.

4.9 Assembly of submersible motor pumps before installation

Submersible motor pump units that are delivered in sub-assemblies have to be assembled during or before installation. For assembly of these submersible motor pump units the specific installation instructions have to be requested from the manufacturer if they have not been delivered with the unit.

5 ELECTRICAL CONNECTION

5.1 Motor



DANGER *All work on the electrical system must be performed by a qualified Electrician in accordance with relevant local, national and international regulations.*

The connection diagrams in the following sections show the basic structure of the connection possibilities and the line arrangement of the mains and motor power cable.

Detailed information about the connection of motors and, if necessary, of control and monitoring devices can be taken from the appropriate circuit diagrams from the control panel manufacturer.

To ensure a good connection with the least possible contact resistance when connecting the power lines, the conductor ends should not be tin-plated.

If the conductor ends are tin-plated, these should be removed. The exposed fine-strand wires must be connected to the electrical supply with suitable terminal screws or by crimping or soldered cable lugs.

5.1.1 Labelling of conductor ends and rotation direction of three-phase motors

The conductor ends of the power cables are labelled so that all three-phase motors rotate clockwise (seen from the coupling ends and towards the shaft) when connected to a clockwise rotating system according to Figure 5.1 to 5.5.

Counter clockwise rotation occurs if two phases of the main connection are transposed from that shown in the clockwise connection diagrams (compare Figures 5-7 to 5-11).

Power supply cables with round or flat cross-sections are connected to the motor. Depending on power consumption or if the installation circumstances are restricted then several single core cables can be used.

5.1.2 Single-phase motors

The direction of rotation of single-phase motors (alternating current motors) is preset by the manufacturer and cannot be changed. The rotation direction preset by the manufacturer can be seen in the data sheet. Connection can only be made using the switching device accompanying the motor for which the labelling of the leads can be found in Figure 5-6 or 5-12.

5.1.3 Motors with one power cable

One four lead power cable is connected to the motor for direct-on-line starting, also auto transformer starting, starting via soft-start and soft-running-out devices as well as for static-frequency operating (compare Figures 5-1 and 5-7), if the current load of the leads allow it.

5.1.4 Motors with two power supply cables, parallel connection



See attachment TI 01-04 E for the interim solution for motors with old and new coloured power supply cables until 01 April 2006.

When a motor's rated current cannot be supplied by one cable it is equipped with two parallel cables.

The connections for a motor with two power cables, with parallel connection, as well as the colour and letter labelling of the conductor ends, is shown in Figure 5-2 or 5-8.

5.1.5 Motors with two power supply cables, parallel connection (open delta-connection)



See attachment TI 01-04 E for the interim solution for motors with old and new coloured power supply cables until 01 April 2006.

For motors with star-delta starting (Figure 5-3 or 5-9), motors whose star connection (Figure 5-4 or 5-10) and/or delta connection (Figure 5-5 or 5-11) is in the control panel, as well as for motors provided with two different voltages, two three-lead and/or one three- and one four-lead power cables are connected to the motor.

5.2 Protective measures against shock-hazard voltage

Protective measures against shock-hazard voltages must be taken according to IEC regulations and the local electricity supply company ordinances.

According to IEC-regulations the protective conductor must be connected directly to the motor on new systems. This also applies when the unit is installed in an inaccessible well.



If there is no earth lead on the motor, a separate earth lead must be connected to the motor using the earth screw supplied. This is labelled with a ⊕ symbol.

5.3 Motor protection

To protect the motor against current overload, a thermal overload relay must be provided. The tripping time of the relay should have temperature compensation to allow for variations in ambient temperature. It should also have accelerated tripping under single-phase conditions.

Tripping reset should only be possible manually.

The setting of the thermal overload relay must be chosen according to the data sheet provided with the pump.

For star-delta motor starters, it is important that the protection relay is in the motor line (see Figure 5-3 or 5-9). The adjusted current level will then be 58%

of the operational current. If the protection relay has been installed in the power line in exception to this rule, the adjusted current is the same as the operational current.

Table 5-1, Overload relay tripping characteristic

I_A		t	L
100 mm (4 in.)	150 mm (6 in.) or larger		
1,05 x I_E		> 2 hours	cold
1,20 x I_E		< 2 hours	warm
5 x I_E	6 x I_E	≤ 10 seconds	cold

I_A = Release current

I_E = operational current (rated current)

t = Delay time until release

L = Operational temperature before overload

The adjustment of the motor protection relay (thermally delayed over current release) must be set according to the value given in the data sheet.

The value given in the data sheet is a standard value for the operating point. If the actual operational current in the operating point of the pump is less than this given value, the motor protection must be adjusted lower so that there is effective protection and malfunctions can be indicated in time.



The motor protection adjustment must never be set higher than the highest permissible value given in the data sheet. Testing the correct operation of a motor protection switch by deliberate single phasing is not permitted!

5.4 Short circuit protection

To prevent a short circuit in the power cable and the motor, safety precautions must be taken according to local regulations.

Guide values for safety fuse sizes can be found in the data sheet.

5.5 Motor connection diagrams

5.5.1 Clockwise rotation

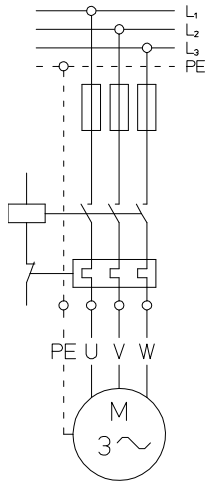

Figure 5-1
Direct-on-line-starting - one power supply cable

	Old	New
U =	black	
V =	light blue	brown
W =	brown	grey
PE =	green/yellow	

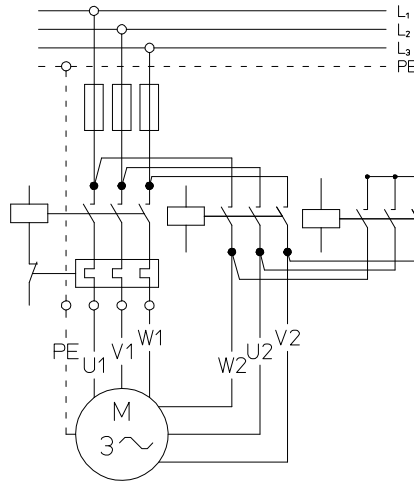

Figure 5-3
Star-delta-starting

	Old	New
U ₁ /U ₂ =	black	
V ₁ /V ₂ =	light blue	brown
W ₁ /W ₂ =	brown	grey
PE =	green/yellow	

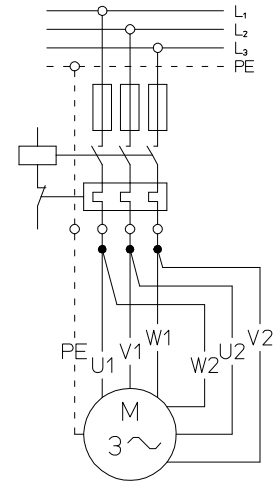

Figure 5-5
Direct-on-line-starting - delta-connection in control panel

	Old	New
U ₁ /U ₂ =	black	
V ₁ /V ₂ =	light blue	brown
W ₁ /W ₂ =	brown	grey
PE =	green/yellow	

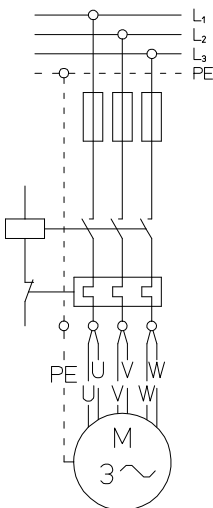

Figure 5-2
Direct-on-line-starting - two power supply cables

	Old	New
U =	black	
V =	light blue	brown
W =	brown	grey
PE =	green/yellow	

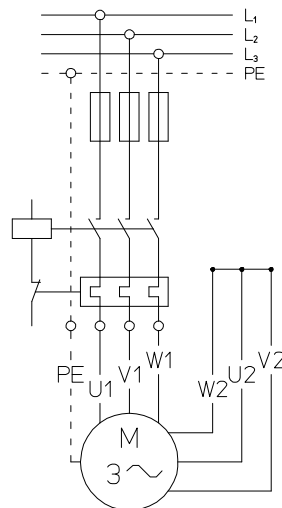

Figure 5-4
Direct-on-line-starting - star-connection in control panel

	Old	New
U ₁ /U ₂ =	black	
V ₁ /V ₂ =	light blue	brown
W ₁ /W ₂ =	brown	grey
PE =	green/yellow	

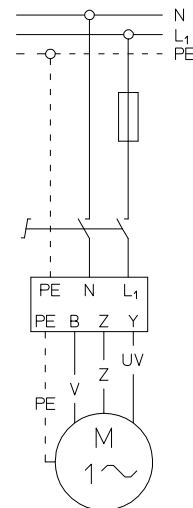

Figure 5-6
Single-phase motor

V =	light blue	
UV =	brown	
Z =	black	
PE =	green/yellow	

5.5.2 Counter-clockwise rotation

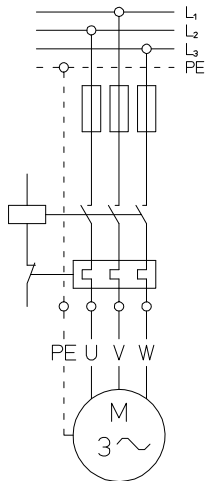

Figure 5-7
Direct-on-line-starting - one power supply cable

	Old	New
U =		black
V =	light blue	brown
W =	brown	grey
PE =	green/yellow	

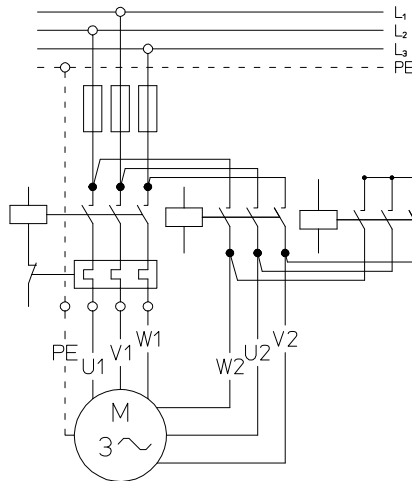

Figure 5-9
Star-delta-starting

	Old	New
U ₁ /U ₂ =		black
V ₁ /V ₂ =	light blue	brown
W ₁ /W ₂ =	brown	grey
PE =	green/yellow	

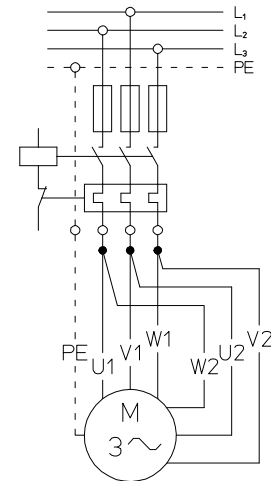

Figure 5-11
Direct-on-line-starting - delta-connection in control panel

	Old	New
U ₁ /U ₂ =		black
V ₁ /V ₂ =	light blue	brown
W ₁ /W ₂ =	brown	grey
PE =	green/yellow	

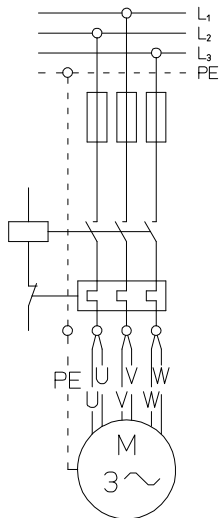

Figure 5-8
Direct-on-line-starting - two power supply cables

	Old	New
U =		black
V =	light blue	brown
W =	brown	grey
PE =	green/yellow	

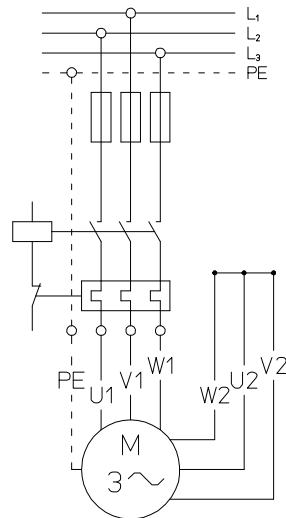

Figure 5-10
Direct-on-line-starting - star-connection in control panel

	Old	New
U ₁ /U ₂ =		black
V ₁ /V ₂ =	light blue	brown
W ₁ /W ₂ =	brown	grey
PE =	green/yellow	

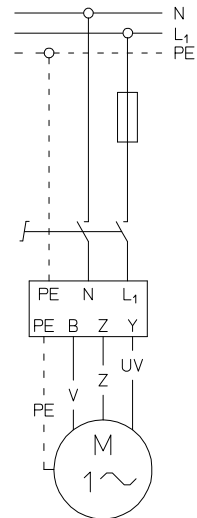

Figure 5-12
Single-phase motor

V =	light blue
UV =	brown
Z =	black
PE =	green/yellow

5.6 Adjustments for soft-starter and soft stop devices

5.6.1 Minimum permissible current limits

Table 5-2

Motor type	Minimum permitted current limit as % of motor rated current
M6	250
M8 up to VNI 14	300
MI 16	350
> MI 16	On request

5.6.2 Minimum start-up voltage

On adjustable devices do not adjust the start-up voltage lower than 55% of the rated voltage.

5.6.3 Permissible ramp-up time

To avoid thermal overload and damage to the bearings DO NOT adjust the ramp-up time above 5 seconds.

On units with a dual ramp-time function or pump function the sum of the dual ramp-time must not exceed 5 seconds. Any other ramp-up time above 5 seconds must be referred to Flowserve for approval.

Should external guidelines state differing values than those stated above, the above values must take precedent. This function should not be used for speed adjustment of the motor.

5.6.4 Permissible ramp-down time

The maximum ramp-down time must not exceed 20 seconds.

On units with a dual ramp-time-function or pump-function the total amount of ramp-time must not exceed 20 seconds. The amount of running-out voltage in this case must not be less than 45% of the rated voltage.

Any other ramp-down time above 20 seconds must be referred to Flowserve for approval.

Should external guidelines state differing values than those stated above, the above values must take precedent. This function should not be used for speed adjustment of the motor.

5.6.5 Starting frequency

Table 5-3

Motor type	Maximum starts and run-outs per hour
M6	8
M8 to MI16	6
> MI16	On request

The number of starts per hour should be spread equally over the hour.

In addition, pay attention to the starting frequency of the soft-start device, which could possibly be less.

5.6.6 Soft starter current limit

To have sufficient reserve for any required additional acceleration torque, the choice of the soft-

start device must be carefully considered to ensure that the starter can deliver at least four times the motor rated current.

5.7 Operation of submersible motors with static frequency converter

5.7.1 General

Motors for operation with a static frequency converter are specially designed. Major operating criteria are the temperature rise of the motor depending on additional losses and the higher voltage stress on static frequency converter operation.

5.7.2 Cooling

Generally, the flow velocity along the motor must be guaranteed for the nominal condition according Table 5-4

Table 5-4

Ambient temperature	Minimum flow velocity
30°C (86 °F)	0.5 m/s (1.64 ft/sec.)
20°C (68 °F)	0.2 m/s (0.66 ft/sec.)

5.7.3 Starting conditions

The minimum frequency of 10 Hertz must be reached within 0.5 seconds.

5.7.4 Permissible operating frequency range

The acceptable operating frequency is from a minimum of 10 Hertz up to a maximum of the nominal frequency. (Refer to the data card.)



In this case the allowable pumping capacity range must be observed. (See section 3.3.1, Normal operating conditions) This may result in a minimum operating frequency above 10Hz.

5.7.5 Maximum voltage stress

The rise in voltage should be less than 500 V/μs and be limited to 1.5 U_N.

5.7.6 Power cable

Shielded power cables should be used at the top of the borehole/well. The cables between the submersible motor and the surface connections must be installed in an adequate Cu-mesh shield that is extensively earthed on both sides.

Any power supply cables must be sized for this higher voltage, depending on the static frequency converter.

Follow the instructions of the manufacturer of the frequency converter regarding the maximum length of the power cables.

The signal cables for temperature sensors should be installed at a distance as far as possible from the high voltage power cables.

5.8 Resistance sensor PT100 (RTD)

Figure 5-13

Standard connection diagram for one PT100 (RTD)

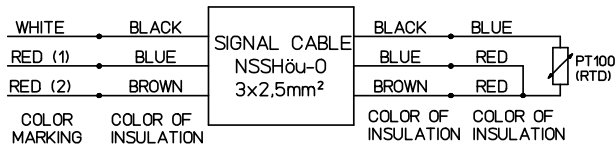
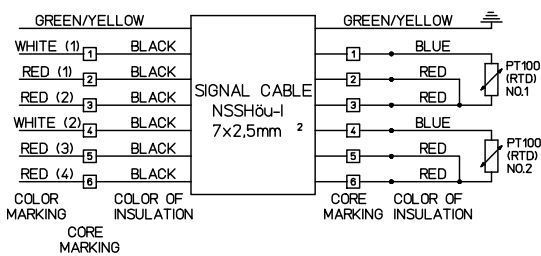

Figure 5-14

Standard connection diagram for two PT100 (RTD)



5.8.1 Adjustment of motor temperature protection relay

The adjustment of the motor temperature protection relays depends on the rated output and the flow conditions along the motor surface. The permissible temperatures are shown on the enclosed data sheet as far as the motor is equipped with Pt100 resistance sensors. Examples of values are:

- At 60 °C (140 °F) high temperature: early warning
- At 65 °C (149 °F) high temperature: motor shut down

6 MOTOR FILLING

The motor must be filled with clean, oil-free and grease-free drinking water, to which antifreeze can be added if there is a risk of freezing.



Never use distilled water.

All motors delivered ready-filled by the manufacturer have antifreeze added which gives protection down to -15 °C (5 °F) unless specifically ordered (certain regions only) filled only with drinking water. For specifically ordered units filled only with drinking water the client is responsible for ensuring that storage and use do not permit freezing.

This standard concentration is always the same unless the customer or operator expressly states a different preference.

For units supplied with a header tank, the fitting of an audible or visual alarm is recommended to monitor the filling level of the motor in case of leakage. This can be, for example, a float switch installed in the overhead tank.

6.1 Antifreeze



Only Type MF motor filling should be used as antifreeze.

6.1.1 Motor filling - Type MF

Type MF motor filling is a liquid consisting of "FSM1" antifreeze and water. "FSM1" antifreeze is manufactured based on propylene-glycol. The mixing ratios must be prepared according to Table 6-1.

Table 6-1

Motor filling type	„FSM1“ % volume	Water % volume	Protection down to
*) MF 15	35	65	- 15°C (5°F)
MF 20	40	60	- 20°C (-4°F)
MF 25	45	55	- 25°C (-13°F)
MF 30	50	50	- 30°C (-22°F)

*) Standard filling

6.1.2 As-delivered state

These instructions apply to the motor types listed in Table 6-2. They are also applicable to Polder pumps, prefixed with a "P". As a general rule, all motors are delivered as shown in Table 6-2.

Table 6-2

Filled	Unfilled
M 6	MX6
M 8	MX8
MI 10	MIX10
VNI 12	
VNI 14	
MI 16	
MI 19	
VNI 22	
MI 26	
VNI 30	

Every motor carries a label indicating its state of filling on delivery.

Yellow label = filled
Green label = unfilled

In all cases the state of filling stated on the label must be observed.

6.1.3 Topping up of pre-filled motors

Topping up of pre-filled motors can be done with potable water without antifreeze if the quantity of topping up liquid is relatively small (1-2%).

6.2 Type of use

The filling of motors depends not only on the motor size and type, but also on the type of use. The standard uses are described below.

6.2.1 Vertical installation

- Normal design
- Normal design in cooling/suction shroud
- Normal design in closed shroud
- Polder pump
- Cavern pump

6.2.2 Horizontal installation

- Normal design
- Normal design in closed shroud
- Pumping station
- Heeling pump

6.3 Filling quantities

The filling quantities stated in Table 6-3 are approximate and may vary slightly due to differing lamination lengths.

Table 6-3

Motor type		Filling quantity	
		[litres]	[US gal]
M 6	MX6	4 to 4,5	1 to 1,2
M 8	MX8	8,5 to 9	2,2 to 2,4
MI 10	MIX10	15	4
VNI 12		35 to 40	9 to 11
VNI 14		53 to 60	14 to 16
MI 16		75	20
MI 19		150	40
VNI 22		200	53
MI 26		300	80
VNI 30		360	95

6.4 Accessories and hardware for filling and topping up

Table 6-4
(Accessories and hardware)

DESIGNATION	DIAGRAM	SIZE	PART. NO.
VENT VALVE		< 0.3 bar	B6523
		> 0.8 bar	
FILLING VALVE		R ³ / ₈ in.	B6514
		R ³ / ₄ in.	
SCREW PLUG		R ³ / ₈ in.	6780
		R ³ / ₄ in.	
		M16 x 1.5	
FILLING SCREW		--	--
PROTECTION CAP		--	0236
FILLING NIPPLE		M10	(2)
		M16	

Motors must be filled and topped up as shown in the descriptions and accompanying diagrams from Section 6.6, *Filling instructions* onwards.

The various components referred to in the individual descriptions and diagrams are summarized here for the sake of simplicity and shown in Table 6-4

(Accessories and hardware)

6.5 General information about filling

The *General information about filling* in this section applies to all motor types, unless stated otherwise in the individual descriptions. If units that require filling are not mentioned in these instructions, special instructions must be requested from the manufacturer.

6.5.1 Filling pressure



To avoid damage to the shaft seal and pressure equalization system, the filling pressure at the inlet of the screw connection must not exceed the maximum pressure stated below when connected to a water supply such as a household tap:

- Motors with the designation MI:.....1,0 bar
- All other motors:.....0,5 bar

6.5.2 Duration of filling

Even though the filling liquid being filled overflows from the venting pipe, there may still be residual air in the motor. It is therefore recommended, to repeat the filling process after approx. 5 minutes to ensure that all cavities are filled with liquid and all air bubbles have escaped from the motor.

6.5.3 Filling valve, filling nipple, filling aids

After filling the motor the hose of the filling pump can be removed from the nipple and the nipple can be screwed out from the filling valve without any risk that the liquid escapes from the motor as the filling valve is designed to prevent any leakage.

The connection apertures for filling the motors vary according to the motor type and model.

The following Table 6-5 shows the filling aids which are required for filling or topping up motors.

Table 6-5

Motor type		Suction shroud	Filling valve	Screw plug	Filling accessory
				*) filling nipple thread size-hose diameter	
M6	MX6	without	without	screw plug	funnel
		with	3/8 in	*) M10 – Ø15/19	pump
M8	MX8	without	without	screw plug	funnel
		with	3/8 in	*) M10 – Ø15/19	pump
MI10	MIX10	without	without	screw plug	funnel
		with	3/8 in	*) M10 – Ø15/19	pump
VNI12		3/4 in		*)M16 – Ø15/19	pump
VNI14					
MI16					
MI19					
VNI22					
MI26					
VNI30					

6.5.4 Filling pump

The filling pump is only suitable for filling motors that are equipped with a filling valve [B6514] in the bottom bearing or thrust bearing housing.

A filling valve [B6514] can be fitted in place of a screw plug [6780]. However, the valve cannot be screwed out again after the motor has been filled; it must remain fitted. Replacing the screw plug does not affect the functioning of the motor.

6.5.5 Sealing cap

The sealing cap [0236] must only be fitted for transportation and storage.



The sealing cap [0236] must always be removed when the motor is put into service.

6.5.6 Filling liquid

If a motor has to be filled or topped up with a mixture of water and antifreeze, this must be prepared in a clean container before filling the motor.

6.5.7 Header tank (optional)

If a header tank is installed it is recommended that it is fitted with a float switch for automatic monitoring of the liquid. This ensures that the motor is always full. The header tank must be not more than 5 m (16.4 ft), corresponding to 0.5 bar (7.25 psi), above the lowest level of the pumped liquid, or the motor, to ensure sealing of the motor. If a greater height cannot be avoided, the manufacturer must be consulted.

6.5.7.1 Pipes

When installing a header tank, pipes with a nominal size of at least 13 mm ($\frac{1}{2}$ in.) must be used between tank and motor for venting and filling the motor.

To ensure the motor is properly filled, the installation of a drain valve in the return pipe below the tank bottom is recommended. This valve must remain open during filling and topping up until the liquid escaping from it is free of bubbles.



The drain valve must never be fitted so that it can shut off the return pipe.

6.5.8 Vent valves

Vent valves are available with different pressure ratings. The appropriate valve is selected according to the purpose for which the submersible motors are to be used. So that filling with liquid does not have to take place against the opening pressure of the vent valve, it can be screwed out for the duration of filling if the installation position allows this.



It is essential that the vent valve is screwed in again after filling.

6.5.9 Accessory pack “Z”

For submersible motors installed horizontally, and in some cases vertically, the vent valves and screw plugs must be exchanged or replaced on site. The parts required for this are supplied in accessory pack “Z”, as shown in Table 6-6, with the respective motor. Relevant instructions are given in the filling

details for the particular motor type and for the specific application.

Table 6-6, Accessory pack “Z”

Item no.	Description	Quantity
B6523	Vent valve	1
6780	Screw plug	1
4510	Sealing ring	3

6.6 Filling instructions

The procedures for filling and topping up submersible motors described below depend on the method of installation and the type of motor used. As a rule it is not possible to use all motor types for all installation methods, and for this reason the following table shows which motors are used as standard for the different installation methods. For special cases not mentioned here, the manufacturer must be consulted.

The relevant section for motor filling must be taken from the data sheet belonging to the corresponding unit. In special cases the filling instructions must be requested from the manufacturer.

Table 6-7

Motor type	Section numbers										
	6.6.1	6.6.2	6.6.3	6.6.4	6.6.5	6.6.6	6.6.7	6.6.8	6.6.9	6.6.10	6.6.11
M6	●		○	●	●				○	○	●
MP6			○			●			○	○	
MX6		●	○	●	●				○	○	●
M8	●		○	●	●				○	○	●
MP8			○				●		○	○	
MX8		●	○	●	●				○	○	●
MI10	●		○	●	●				○	○	●
MIP10			○				●		○	○	
MIX10		●	○	●	●				○	○	●
VNI12		●	○	●	●				○	○	●
VNI14		●	○	●	●			●	○	○	●
MI16		●	○	●	●			●	○	○	●
MI19		●	○								
VNI22		●	○								
MI26		●	○								
VNI30		●	○								

● = standard

○ = optional



Not currently scheduled

The following instructions are only relevant for filling and topping up before the first installation, for motors without a header tank. Before installation ensure that the motors do not have any leaks.

For installations with a header tank, the liquid level must be monitored. Installation of an automatic level control is recommended.

6.6.1 Filling and topping up with a funnel
(See Figure 6-1)

- a) Position the motor vertically and prevent the unit from falling over.
- b) Remove the cap [0236] of the vent valve [B6523] with a screwdriver or similar tool.

CAUTION *The cap [0236] is only used for protection during transportation and must always be removed before installation.*

- c) Screw out the vent valve [B6523] with a ring wrench or socket wrench (size 17).

CAUTION *Handle seal ring [4510.10] with care.*

- d) Fit together the two-part funnel [1], and insert it into the threaded hole of the removed vent valve.
- e) Fill or top up until liquid escapes from the vent opening.
- f) Screw the vent valve [B6523] back in with its seal ring [4510.10].

Figure 6-1

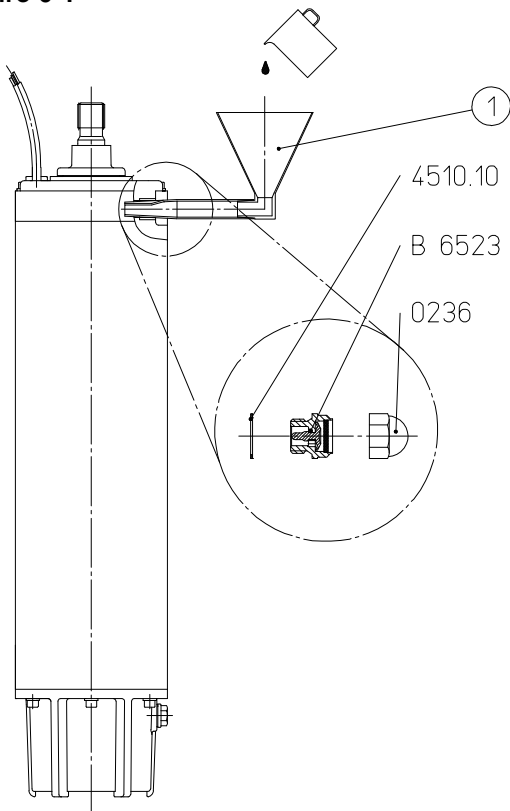

6.6.2 Filling and topping up with filling pump
(See Figure 6-2)

- a) Position the motor vertically and prevent the unit from falling over.
- b) Remove the cap [0236] of the vent valve [B6523] with a screwdriver or similar tool.

CAUTION *The cap [0236] is only used for protection during transportation and must always be removed before installation.*

- c) Screw out the inner screw plug [0168] of the filling valve [B6514].

CAUTION *Handle seal ring [4510] with care.*

- d) Screw the filling nipple supplied [2] into the screw plug threaded hole.

Note: *The connections of the filling nipple [2] are different sizes. Fit the relevant filling nipple [M 10 or M 16] into the threaded hole.*

- e) Fit the hose end of the filling pump over the nipple [2] and place the pump into a container [3] filled with the filling liquid.
- f) Fill the motor until the liquid escapes from the vent valve [B6523] with no bubbles.
- g) Pull the pump hose off the nipple and screw out the nipple.
- h) Refit the screw plug [0168] into the filling valve [B6514] together with the seal ring [4510].

Figure 6-2

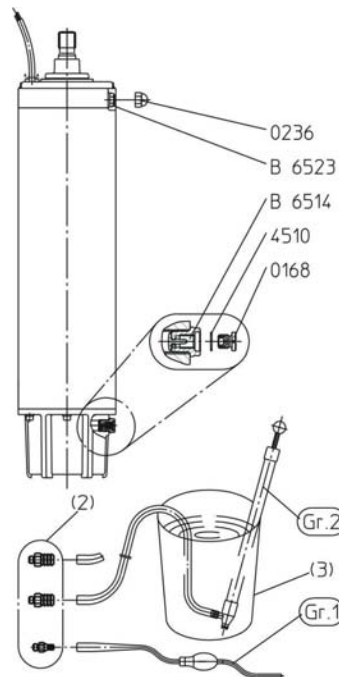

6.6.3 Motors with header tank for vertical installation (See Figure 6-3)

Note: *Motors for this type of installation are specially equipped.*

- Position the motor vertically and prevent the unit from falling over.
- Screw out the adapter with vent valve [2] from the vent pipe "V".
- Remove the adapter and plug [3] from the filling pipe "F".
- Fill the motor before installation using a funnel [4] into filling pipe "F" until the liquid escapes with no bubbles from vent pipe "V".
- Install the motor and fill the connected filling and venting pipes during installation. (If using multiple pipes it is advisable to fill the subsequent pipes with liquid immediately after fitting to test the connections for leakage.)
- After installing the header tank [1] and connecting the pipes to it, fill the tank with liquid up to the mark indicated. When filling the tank, ensure that no liquid enters the vent pipe "V".

Figure 6-3

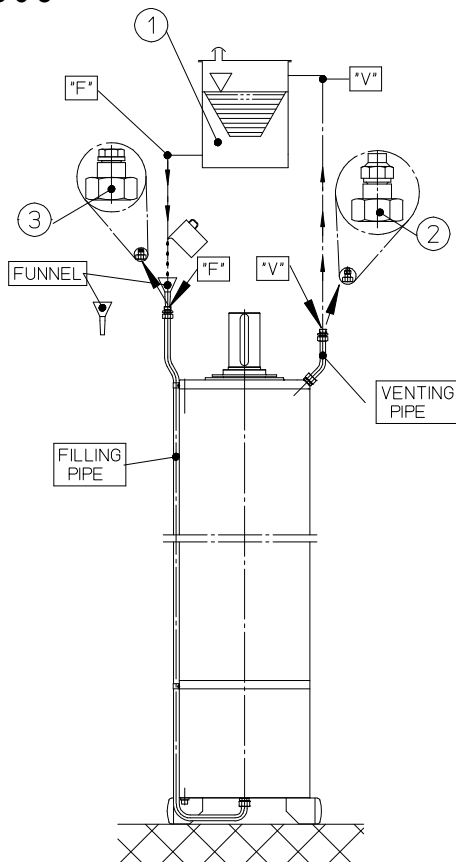

6.6.4 Filling and topping up units with cooling/suction shroud (See Figure 6-4)

- Position the unit vertically and prevent the unit from falling over.
- Remove the inner screw plug [0168] of the filling valve [B6514].

CAUTION *Handle seal ring [4510] with care.*

- Screw the filling nipple into the threaded hole from which the screw plug [0168] was removed.

Note: *The hose connections of the filling nipples [2] are different sizes. The correct one for the thread size (M 10 or M 16) and the pump hose must be fitted.*

- Fit the hose end of the filling pump over the filling nipple and place the pump in a container [3] filled with liquid.
- Fill the motor until the liquid escaping from the vent valve (B 6523) contains no bubbles. (As the area in which the vent valve [B6523] is fitted is not accessible to inspection, a relatively large amount of liquid should be allowed to escape to ensure that the motor is completely full.)
- Pull the filling pump hose off the filling nipple [2] and screw out the filling nipple.
- Refit the screw plug [0168] into the filling valve [B6514] together with its seal ring [4510].

Figure 6-4

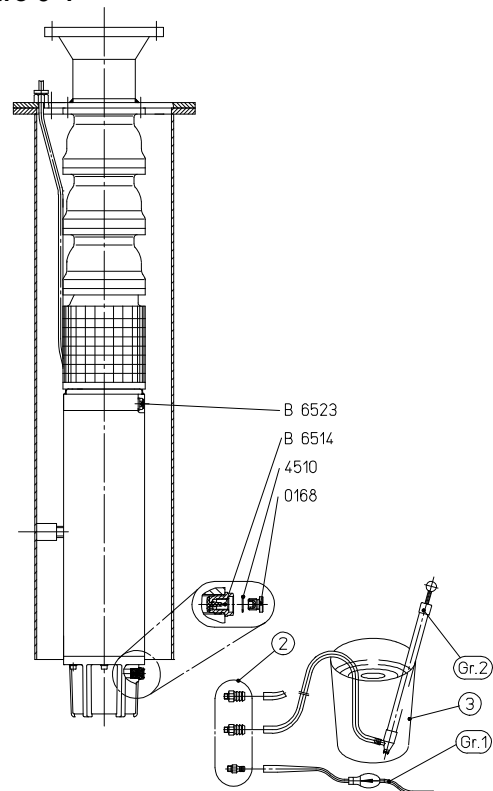

6.6.5 Filling and topping up units with shrouds for vertical installation
(See Figure 6-5)

Note: *This section is also valid for horizontal installation of 6 in. (150 mm), 8 in. (200 mm) and 10 in. (250 mm) units with shrouds.*

- a) Position the unit vertically and prevent it from falling over.
- b) Remove the screw plug [5] from the filling connection [1].

CAUTION *Handle seal ring [3] with care. When undoing screw plug [5] hold the filling connection [1] securely with a wrench (size 27) so that the pipe or hose fitted inside the shroud is not twisted.*

- c) Screw the M 10 filling nipple supplied [2] into the threaded hole of the screw plug.
- d) Fit the hose end of the filling pump over the filling nipple [2] and place the pump in a container filled with liquid [4].
- e) Fill the motor until the liquid escaping from the vent valve (B6523) contains no bubbles. As the area in which the vent valve [B6523] is fitted is not accessible to inspection, a relatively large quantity of liquid should be allowed to escape from it to ensure that the motor is completely full. If the unit is fitted with a foot valve [6] it must be removed to allow the overflow of liquid to be monitored.
- f) Pull the filling pump hose off the filling nipple [5] and screw out the filling nipple.
- g) Refit the screw plug [5] into the filling connection [1] together with its seal ring [3].

CAUTION *When tightening the screw plug [5] hold the filling connection [1] securely with a wrench [size 27] so that the pipe or hose fitted inside the shroud is not twisted.*

Figure 6-5

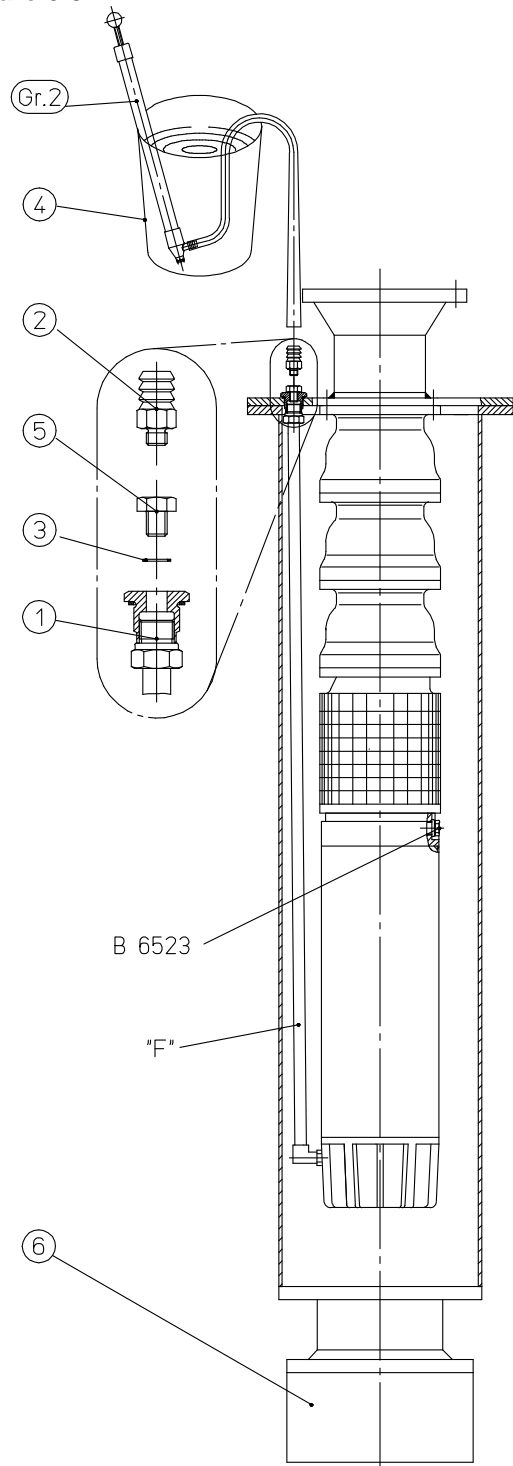

6.6.6 MP6 Polder motors

(See Figure 6-6)

- a) Position the unit with the motor vertical and prevent the unit from falling over.
- b) Screw off the cap nuts including plug [1] from the filling and return pipes [A].
- c) To fill or top up the motor, insert a funnel [5] into one of the two pipes and pour in the liquid until it escape with no bubbles from the other pipe.

Note: *Filling and vent pipes of this type of polder motors do not generally have identifying markings, therefore either pipe can be selected.*

- d) To enable the filling of the motor with a pump [3] a filling valve [9701.259/7] together with an adapter piece [1078.615/2] must be fitted onto one of the pipes. For the supplementary installation the following parts (not supplied as standard) are required:
 - 1 x adapter piece TLN 1078.615/2
 - 1 x filling valve TLN 9701.259/7
 - 1 x filling nipple [2] TLN 9452.558/2
 - 1 x filling pump [3] with filling hose

Alternatively, large motors can be filled with a filling pump via a pressurised water connection.

CAUTION *The filling pressure at the inlet of the screw connection must not exceed 0.5 bar (7.25 psi) maximum when connected to a water supply such as a household tap.*

- e) After filling, unscrew the filling valve and the adapter piece and screw the cap nuts including plugs [1] back onto the filling and return pipes.

Figure 6-6

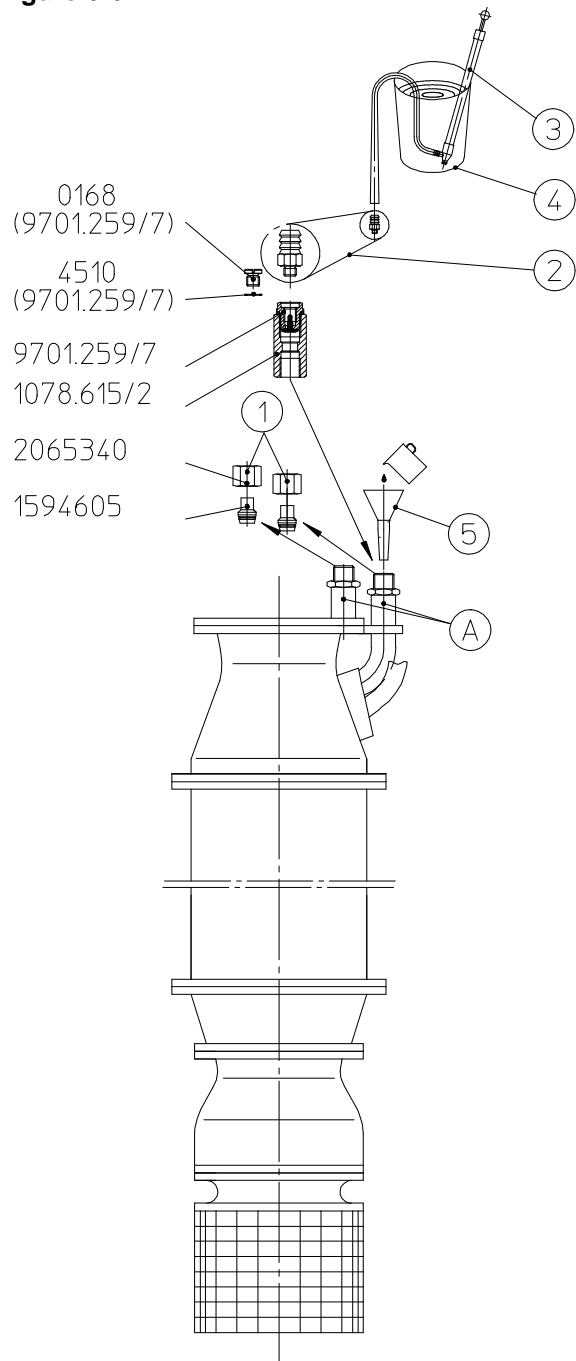

6.6.7 Filling and topping up MP 8/MIP 10 motors for polder pumps using a filling pump (with filling and venting pipe on top)

(See Figure 6-7)

- a) Position the unit with the motor vertical and prevent the unit falling over.
- b) Screw off the cap nuts with plug [1a] (thread size M12x1.5) from the venting pipe "V" and [1b] (thread size M16x1.5) from the filling pipe "F".
- c) Screw in a filling valve [9701.259/7] together with an adapter piece [1078.615/2] onto the thread for the cap nut [1b].
- d) Unscrew the plug screw [0168] from the filling valve [9701.259/7] and fit a filling nipple [2] into the threaded hole.
- e) Using the filling pump [3] fill the motor until the liquid escapes from the return pipe "V" with no bubbles.
- f) After filling, unscrew the adapter piece and the filling valve and screw the cap nut and plug screws back onto the filling and return pipes. For the supplementary installation the following parts (not supplied as standard) are required:
 - 1 x adapter piece TLN 1078.615/2
 - 1 x filling valve TLN 9701.259/7
 - 1 x filling nipple [2] TLN 9452.558/2
 - 1 x filling pump [3] with filling hose

Large motors can be filled via a pressurised water connection. For this a hose can be pulled onto the filling nipple [2].



The filling pressure at the inlet of the screw connection must not exceed 0.5 bar (7.25 psi) maximum when connected to a water supply such as a household tap.

Figure 6-7

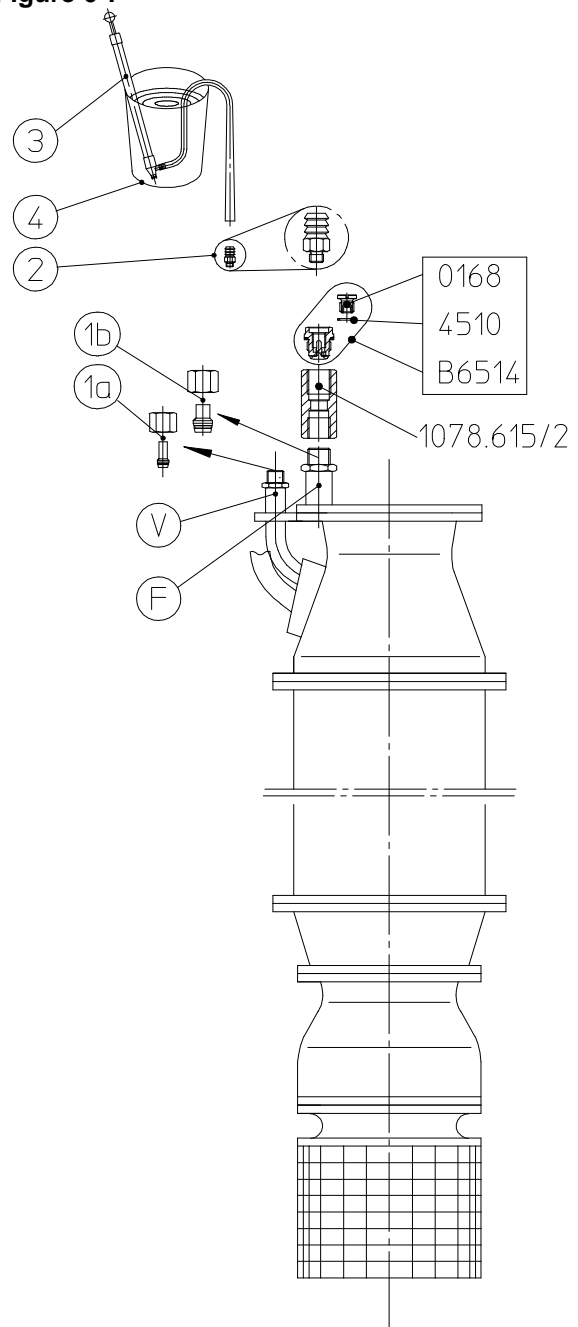

**6.6.8 Filling motors with external pressure equalization (outside compensation pipe)
(See Figure 6-8)**

- a) Position the unit with the motor vertical and prevent the unit from falling over.
- b) Remove the vent screw [1].
- c) Remove the inner screw plug [0168] of the filling valve [B 6514].



Handle seal ring [4510] with care.

- d) Screw the filling nipple [2] into the threaded hole from which the screw plug [0168] was removed.

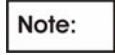

The hose connections of the filling nipples are different sizes. The correct one must be fitted according to the thread size (M 10 or M 16) and the pump hose size.

- e) Fit the hose end of the filling pump supplied over the nipple [2] and place the pump in a container [3] filled with liquid.
- f) Fill the motor until the liquid escaping from the opening for the vent screw [1] contains no bubbles. Refit the vent screw [1].
- g) Continue filling the motor via the filling valve [B6514] until the liquid escaping from the vent valve [B 6523] contains no bubbles.
- h) For filling the motor, it is recommended to completely screw out the vent valve.
- i) Refit the screw plug [0168] into the filling valve [B6514] together with its seal ring [4510].
- j) Remove the inner screw plug [0168] of the filling valve [4].



Handle seal ring [4510] with care.

- k) Screw the supplied filling nipple [2] into the threaded hole from which the screw plug [0168] was removed, and fill the expansion pipe [5] until the liquid escapes from the top end, "U".
- l) Screw the filling nipple out of the filling valve [4] and refit the screw plug [0168] into the filling valve together with the seal ring [4510].

Figure 6-8

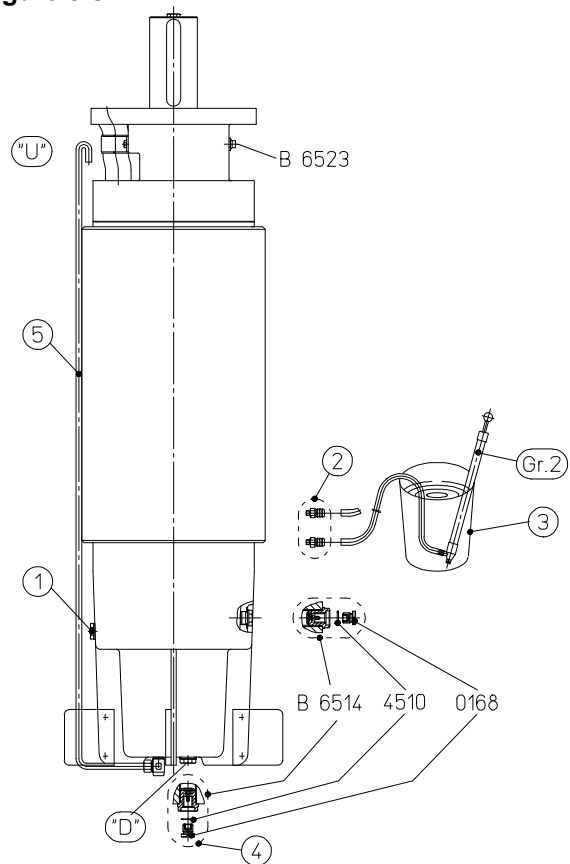

6.6.9 Motors for horizontal installation
 (See Figure 6-9 A, as delivered state)
 (See Figure 6-9 B, operating state)

- a) Fill or top up the motor before installation, as described in Section 6.6.1 or 6.6.2.
- b) Replace the vent valve [B6523] by a screw plug [6780] (marked "A".)
- c) Put the motor or complete pump unit into its horizontal position for normal use so that the carriers located on the stator housing (marked "B") are at the highest point of the stator housing.
- d) Screw the two plugs [6780] out of the carriers and fit vent valves [B6523] in their place (marked "B").
- e) Exchange the screw plugs [6780] for vent valves [B6523]. This must be carried out immediately before installation on site.

- f) The screw plug [6780] and one of the two vent valves [B6523] mentioned above must be taken from the accessory pack supplied with the motor. (See section 6.5.9, Accessory pack "Z") For the second vent valve [B6523], use the one that has been screwed out, as described in b) above.
- g) All seals [4510] for replacement are contained in Accessory pack "Z".



After installing the vent valves, the motor must not be rotated or positioned vertically.

- h) Top up the motor again in its installed position until the liquid escaping from the vent valve [B6523] contains no bubbles.
- i) Pull the filling pump hose off the filling nipple [2] and screw out the filling nipple (if the filling has been carried out with a filling pump) and refit the screw plug [0168] into the filling valve [B6514] together with the seal ring [4510].

Figure 6-9 A

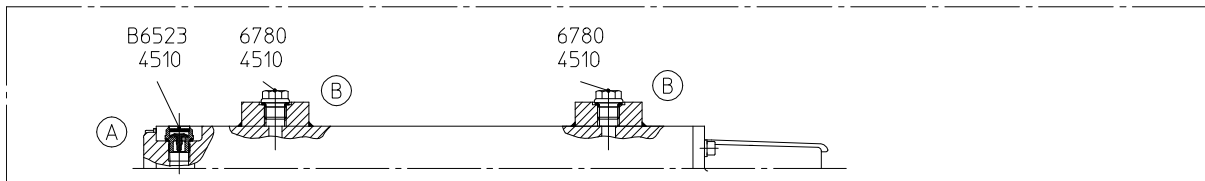
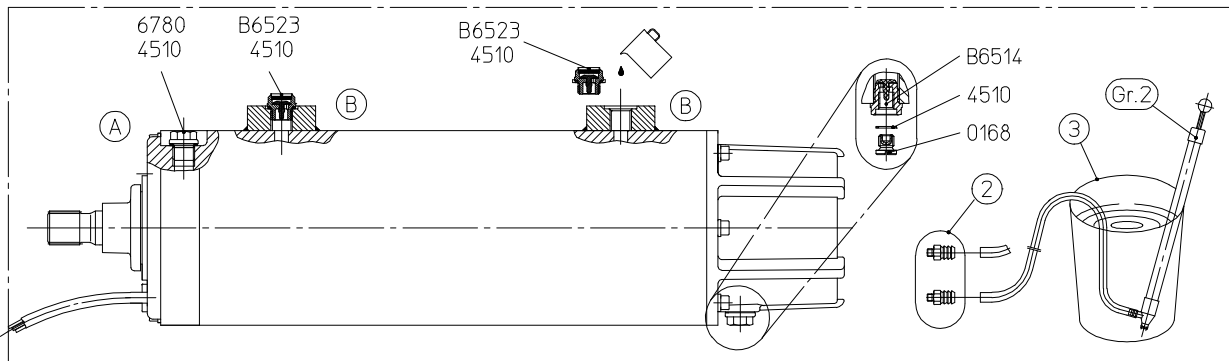

Figure 6-9 B



6.6.10 Motors with header tank for horizontal installation (Figure 6-10)

Note: *Motors for this type of installation must be specially equipped.*

- a) Put the motor horizontally with the vent valve [B6523] at the top. Screw out the vent valve [B6523] and replace it with a screw plug [6780] from the accessory pack (see section 6.5.9 Accessory pack "Z".)
- b) Rotate the motor so that the carriers located on the stator housing are at the top. Remove the screw plugs [6780] from the carriers, and screw the pipe connectors [2 and 3] into the threaded holes (M16 x 1.5).
- c) Fit the pipes "V" into the connectors [2 and 3] up to the points marked "Y" and close the pipe on the end.
- d) Rotate the motor so that the filling valve [B6514] is at the top. Screw out the filling valve [B6514] and screw a pipe connector [4] into the threaded hole (R 3/8 in. or R 3/4 in.).
- e) Fit the pipes/hoses ["F"] into the connector [4] up to the points marked "X" and close the pipe on the end.
- f) Install the motor horizontally and lay further pipes up to the header tank [1].
- g) When carrying out this work, it is essential to ensure that no liquid escapes from pipes "V" and "F". If necessary, temporarily plug the pipes at points "X" and "Y" until the pipes have been connected to the header tank [1]. If using multiple pipes, it is advisable to fill the subsequent pipes with liquid immediately after fitting to test the connections for leakage.
- h) After installing the header tank [1] and connecting the pipes to it, fill the tank with liquid up to the level mark.

Figure 6-10

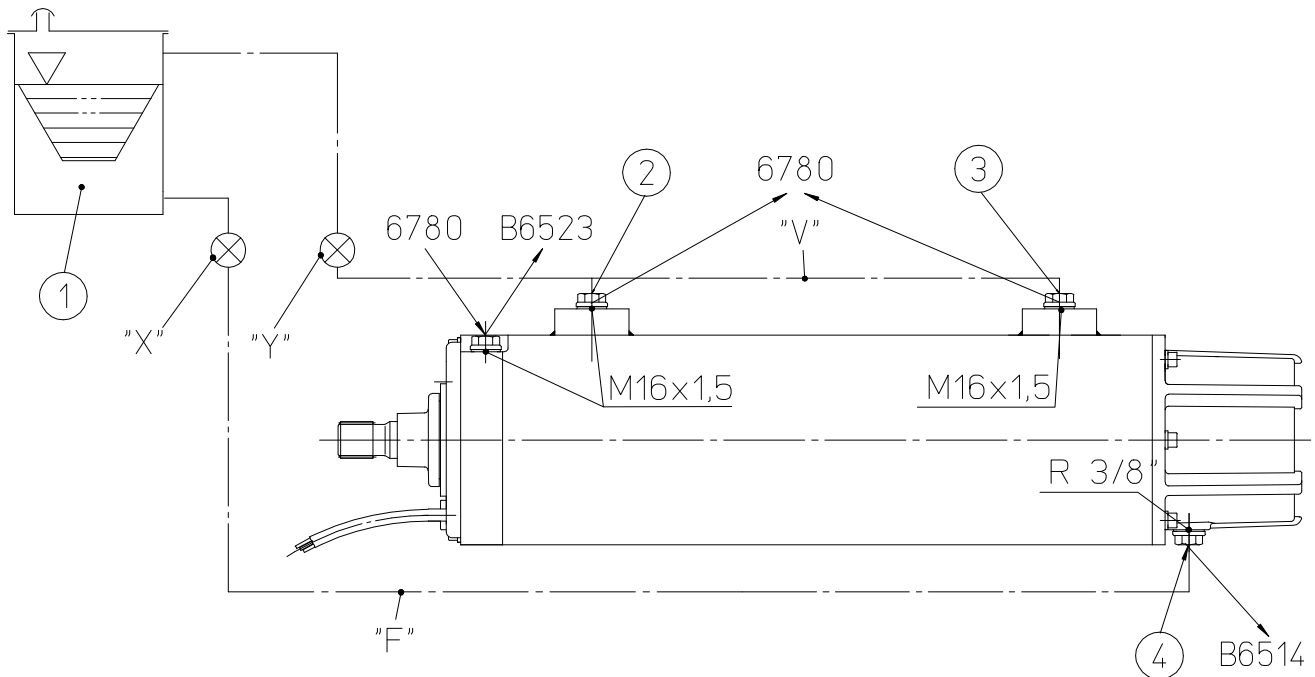

6.6.11 Filling and topping up units with shroud for horizontal installation
(See Figure 6-11)

This instruction is only valid for units above 12 in (300 mm). For units up to 12 in. (300 mm), see section 6.6.5 *Filling and topping up units with shrouds for vertical installation.*

- a) Position the unit with motor vertically and prevent the unit to tilt over.
- b) Remove the screw plugs [4] from the screw-in sockets "F" (filling pipe) and "V" (vent pipe).

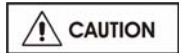

Handle seal ring [3] with care. When undoing the screw plugs [4], hold the screw-in sockets [1] securely with a wrench (size 27) so that the pipes or hoses fitted inside the shroud are not twisted.

- c) Screw the filling nipple [2] (thread size M 10) into the threaded hole of the filling pipe "F".

- d) Fit the hose end of the filling pump over the filling nipple [2] and place the pump in a container [5] filled with liquid.
- e) Using the filling pump, fill the motor until the liquid escaping from the threaded hole of vent pipe "V" contains no bubbles.
- f) Pull the filling pump hose off the nipple and screw out the filling nipple [2].
- g) Refit the screw plugs [4] into the screw-in sockets together with the seal rings [3].
- h) When tightening the screw plugs [4] hold the screw-in sockets [1] securely with a wrench (size 27) so that the pipes or hoses fitted inside the shroud are not twisted.

Figure 6-11

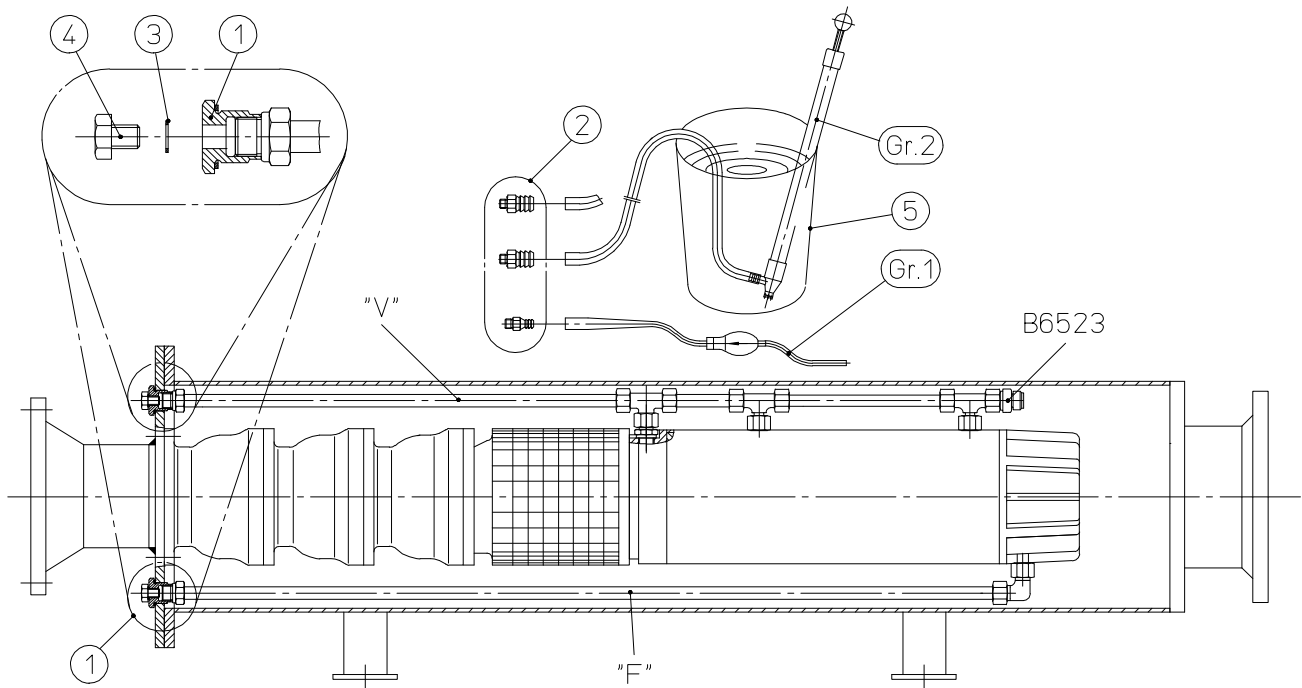

7 COMMISSIONING, START-UP AND SHUTDOWN

7.1 Commissioning

7.1.1 General notes

Due to the slender design of the submersible motors, different current values can be measured in the individual phases. This is especially true for two-pole motors. These differences can be reinforced by voltage differences between the phases already present from the line side.

This effect can be reduced to a minimum by transposing the line side phase connections in clockwise order.

Details concerning the electrical switchgear must be taken from the Operating Instructions from the control panel manufacturer.

For practical reasons, the pressure pipe downstream of the slide valve is first closed when the pumped water is free of sand and/or impurities.

7.1.2 First switching on

After the pump unit has been fully installed and all pipelines have been connected upstream and downstream as far as the control valve, the control valve is closed except for a small gap for venting the ascending pipeline. After this, the unit can be switched on.



S-type pump units (pumps with axial impellers) must never be started against a closed slide valve. Overloading could then occur, with consequent damage to the motor.

After switching on, the pressure at the manometer must be greater than the head given in the data sheet minus the water depth (W_t).

If the pressure at the manometer is less than that given in the data sheet, the drive is rotating in the wrong direction. When the direction of rotation is incorrect, the pump will have no or extremely reduced performance.



The unit must not be driven for longer than three minutes in the wrong direction.

If incorrect rotation occurs, exchange two phases with one another on the motor power cable in the control panel.



Do not transpose anything on the star-delta contactor combination.

Single-phase machines are wired within the motor so that they have the correct rotation on every supply system with the prescribed voltage when connected. The direction of rotation on these machines cannot be changed.

As the empty ascending pipeline is being filled, the ammeter may show a higher current than in the data sheet even after the switching-on current has decayed during the initial switching-on.

After this the operational current must be lower than the highest permissible current given in the data sheet.

Open the slide valve slowly, so that the well is not overloaded by too great a flow and sand is also not swept up. Watch the current consumption of the motor on the ammeter whilst opening the valve.

Slowly open the slide valve until the ammeter just shows the operational current according to the data sheet.

When the design operating point for the pump unit has been reached, current consumption must approximate with that given in the data sheet.

The fitting conditions and electrical connections must be checked once again if this is not the case.

The pressure pipe can be connected if there are no abnormalities during and after the test run, if this has not yet been carried out.

7.2 Operation

After the unit has operated for a period of time, it is possible that a minimal readjustment of the motor circuit breaker may be required, due to changed operating conditions, for example by the sinking of the water level.



Do not select a motor protection adjustment setting greater than the highest permissible value given in the data sheet.

For monitoring the water level in the well and in the header tank, we recommend water level detectors or water level measuring units.

7.2.1 Starting frequency

The amount of regularly spaced starts per hour can be found in the data sheet. More frequent starts are only permissible if agreed with the manufacturer.

Table 7-1

Maximum number of permissible starts in sequence	
Cold motor	3 starts
Warm motor	2 starts
Resting time after each cycle	5 minutes

It is suggested that the motor is protected by a time relay against unauthorised reconnection.

7.3 Switching off the unit

To minimize water hammers the control valve (see item no. 8 on Figure 3-1) must be closed before the unit will be switched off. After the valve has been closed the unit must be switched off within 2 to 3 minutes.

8 MAINTENANCE

Submersible pump units normally run without needing maintenance.

If a pump unit should stand idle for a lengthy period of time, perform a 10 minute test run every month, so that potential malfunctions can be recognized in time.



The pump unit must be completely submersed in pumping medium for this test run.

8.1 General information

As the units are normally used at very great depths, it is recommended that the following checks are performed and recorded at regular intervals, in order to recognize malfunctions in time:

- Current consumption
- Head
- Flow
- System voltage
- Operating hours
- Insulation test
- Temperature (only if temperature sensors PT100 [RTD] exist)

Current consumption of the motor is the most important test for monitoring the unit.

For finding problems, their cause and elimination, see Section 9, *FAULTS; CAUSES AND REMEDIES*.

8.2 Pump units

The pump unit can be operated without maintenance, insofar as there are no irregularities in operation or pumping, caused by sand or a corrosive pumping medium, that make premature removal necessary.

Fluctuating and/or rapidly increasing current consumption indicate mechanical problems in the pump or motor.

Strong oscillation of the pressure, and at the same time of the ammeter, can be caused by irregular water inflow.

8.3 Measuring insulation

8.3.1 Motor including power supply cable

Before initial starting, or after long storage or idle time, the insulation resistance of the drive must be measured.



DANGER *During and after measurement, the conductor ends of the motor power cable*

and/or the connection terminals may carry dangerous voltage (up to the test voltage) and must not be touched. Before measuring, ensure that there is no line voltage.

To measure the insulation of the system, disconnect all leads of the power supply cable.

All leads must be carefully cleaned to remove dirt or corrosion. Follow the instructions given with the insulation measurement instrument.

Insulation measurement is always performed with a measuring-circuit voltage of 500 volts. The value must be read for the duration of a minute.

The motor windings or power cable, charged up to the measuring-circuit voltage, must be discharged after measurement using the insulation-measuring device.

The minimum insulation resistance and critical insulation resistance limits for measurements at a winding temperature of 25 °C (77 °F) are as follows:

New Motors	Over 500 MΩ
Minimum insulation value of new motors with power supply cable	5,0 MΩ
Critical insulation value after longer operation time	0,5 MΩ

If the insulation value is near the minimum causes could be increased air humidity and/or dirty, moist conductor ends or a winding temperature higher than 25 °C (77 °F).

A relatively low insulation resistance does not definitely show that the motor will break down due to insulation problems.

However the insulation must be inspected, if after measurements over a longer period, an extreme drop in the insulation resistance occurs within a short time.

If the insulation resistance falls below the minimum value, the cause must be determined or the faulty part (power cable, line connection or windings) identified and the insulation weakness removed.

8.3.2 Motors with one power supply cable



DANGER *The cable conductors become charged with the test voltage while measuring the blank ends of the power cable and they must therefore be insulated.*

Only one lead must be measured to earth as all other leads are internally connected.

8.3.3 Motors with two power supply cables



DANGER *The cable conductors become charged with the test voltage while measuring the blank ends of the power cable and they must therefore be insulated.*

The following insulating measurements of the winding and power cables are possible, depending on the internal motor connections:

- two cables on open phase connection - measurement to be taken between each core of the cable and earth.
- two parallel cables with internal star connection - measurement to be taken between one core and earth.
- two parallel cables with individual coil systems (star or delta connection) - measurement to be taken between one core of each system and earth.

8.3.4 Checking insulation resistance of PT100 (RTD)

All cores of the temperature sensors PT100 (RTD) have to be connected together to check the insulation resistance. The motor, together with its installed one or two PT100 (RTD) sensors and the signal cable, need to be submerged in water.

The testing voltage must not be higher than 500 volts.

The insulation resistance of a new unit should be at least 250 MΩ.

The critical insulation resistance, after a long time in service should be at least 0.25 MΩ.

The insulation resistance values apply for an ambient temperature of 40 °C (104 °F). At lower values the connection between the PT100 and the signal cable must be separated and the measurements re-taken.

8.3.5 Continuity check

The continuity check must be carried out with a resistance measurement bridge at a voltage not higher than 5 volts.

To check the correct temperature values of the PT100 (RTD) the ambient temperature must be known.

When units are installed it is possible to test the PT100 (RTD) provided the exact temperature of the well water is known.

8.3.5.1 One temperature sensor

Carry out the three measurements in Table 8-1:

Table 8-1

Measurement	Colour code
1	white – red 1
2	white – red 2
3	red 1– red 2

The difference between the readings of measurements 1 and 3 or 2 and 3 is the resistance of the RTD (PT100).

These values should be compared with table 8-3.

8.3.5.2 Two temperature sensors

Carry out the six measurements in table 8-2:

Table 8-2

Measurement	Colour code	PT 100
1	white 1 – red 1	No. 1
2	white 1 – red 2	
3	red 1 – red 2	
4	white 2 – red 3	No.2
5	white 2 – red 4	
6	red 3 – red 4	

The difference between the readings of measurements 1 (4) and 3 (6) or 2 (5) and 3 (6) is the resistance of the RTD (PT100) No.1 (No. 2).

These values should be compared with table 8-3.

Table 8-3

°C (°F)	Ω	°C (°F)	Ω	°C (°F)	Ω
1 (33.8)	100.39	36 (96.8)	113.86	71 (159.8)	127.34
2 (35.6)	100.77	37 (98.6)	114.25	72 (161.6)	127.72
3 (37.4)	101.16	38 (100.4)	114.63	73 (163.4)	128.11
4 (39.2)	101.54	39 (102.2)	115.02	74 (165.2)	128.49
5 (41.0)	101.93	40 (104.0)	115.40	75 (167.0)	128.88
6 (42.8)	102.31	41 (105.8)	115.79	76 (168.8)	129.26
7 (44.6)	102.70	42 (107.6)	116.17	77 (170.6)	129.65
8 (46.4)	103.08	43 (109.4)	116.56	78 (172.4)	130.03
9 (48.2)	103.47	44 (111.2)	116.94	79 (174.2)	130.42
10 (50.0)	103.85	45 (113.0)	117.33	80 (176.0)	130.80
11 (51.8)	104.24	46 (114.8)	117.71	81 (177.8)	131.19
12 (53.6)	104.62	47 (116.6)	118.10	82 (179.6)	131.57
13 (55.4)	105.01	48 (118.4)	118.48	83 (181.4)	131.96
14 (57.2)	105.39	49 (120.2)	118.87	84 (183.2)	132.34
15 (59.0)	105.78	50 (122.0)	119.25	85 (185.0)	132.73
16 (60.8)	106.16	51 (123.8)	119.64	86 (186.8)	133.11
17 (62.6)	106.55	52 (125.6)	120.02	87 (188.6)	133.50
18 (64.4)	106.93	53 (127.4)	120.41	88 (190.4)	133.88
19 (66.2)	107.32	54 (129.2)	120.79	89 (192.2)	134.27
20 (68.0)	107.70	55 (131.0)	121.18	90 (194.0)	134.65
21 (69.8)	108.09	56 (132.8)	121.56	91 (195.8)	135.04
22 (71.6)	108.47	57 (134.6)	121.95	92 (197.6)	135.42
23 (73.4)	108.86	58 (136.4)	122.33	93 (199.4)	135.81
24 (75.2)	109.24	59 (138.2)	122.72	94 (201.2)	136.19
25 (77.0)	109.63	60 (140.0)	123.10	95 (203.0)	136.58
26 (78.8)	110.01	61 (141.8)	123.49	96 (204.8)	136.96
27 (80.6)	110.40	62 (143.6)	123.87	97 (206.6)	137.35
28 (82.4)	110.78	63 (145.4)	124.26	98 (208.4)	137.73
29 (84.2)	111.17	64 (147.2)	124.64	99 (210.2)	138.12
30 (86.0)	111.55	65 (149.0)	125.03	100 (212.0)	138.50
31 (87.8)	111.94	66 (150.8)	125.41		
32 (89.6)	112.32	67 (152.6)	125.80		
33 (91.4)	112.71	68 (154.4)	126.18		
34 (93.2)	113.09	69 (156.2)	126.57		
35 (95.0)	113.48	70 (158.0)	126.95		

8.4 Removal of the pump unit

When lifting the pump to withdraw it, take account of the pump weight plus the weight of the water column contained within the riser pipe if the pump unit does not have a check valve with drain holes. (If the check valve does have drain holes the weight of the water column is not applicable.)

8.5 Overhaul of the pump unit

The structural design of a submersible pump unit makes assembly and disassembly possible using simple tools.

In case of removal, installation instructions specific to the unit can be requested from the manufacturer.

It is recommended, however, that the unit is examined by Flowserve technicians or that it is overhauled at a Flowserve authorized service depot.

When taking the unit out of service and before starting removal work, studying these operating instructions once again is recommended.

For special advice regarding additional information or for purchasing replacement parts, the following information is required:

- Serial number of the unit from the nameplate (also printed on the stator housing)
- Description of the unit type according to the nameplate
- For questions regarding replacement parts:
 - item number from the sectional drawing
 - part description and number as shown in the parts list
 - quantity of parts required
- For problems:
 - short description of the problem and/or the effects
 - description of the faulty part(s) as shown in the parts list

Please refer all questions directly to the main factory or to a factory representative.

9 FAULTS; CAUSES AND REMEDIES

FAULT SYMPTOM									
Motor protection triggered									
↓	Pump does not start								
↓	Motor overheats								
↓	Unit runs but does not pump								
↓	Unit vibrates or is noisy								
↓	Motor loses filling liquid								
↓	Pump requires excessive power								
↓	Pump does not draw in water at start								
↓	Insufficient pressure developed								
↓	Insufficient capacity developed								
								PROBABLE CAUSES	POSSIBLE REMEDIES
A. System problems									
•			•	•	•	•	•	Suction lift too high or level too low.	Check $NPSH_A > NPSH_R$ proper submergence.
			•		•	•	•	Excessive amount of air or gas in liquid.	Check submergence. Losses on suction strainer.
							•	Pipe work defective. Leakage in pipe work..	Check pipe work.
			•		•	•	•	Foot valve too small.	Investigate replacing the foot valve.
	•						•	Foot valve partially clogged.	Clean foot valve. Investigate replacing foot valve.
	•	•	•		•	•	•	Inlet of suction housing insufficiently submerged. Fitting depth inadequate.	Check out system design. Install the unit deeper.
•		•		•		•	•	Total head of system does not correspond to pump characteristics.	Check discharge head and head losses in discharge pipe at the valve settings. Check back pressure is not too high.
•				•		•		Total head of system lower than pump design head.	Throttle at discharge valve or ask Flowserve if the impeller can be trimmed.
				•				Specific gravity of liquid different to design.	Consult Flowserve.
•			•					Operation at very low capacity.	Measure value and check minimum permitted.
•	•	•	•	•				Operation at high capacity.	Measure value and check maximum permitted.
•	•	•	•	•				Slide valve closed. Pressure pipe not free.	Check slide valve. Check piping.
B. Mechanical problems									
			•					Improperly designed foundation.	Check setting of base plate: tighten, adjust, grout base as required.
	•		•	•				Shaft bent.	Check shaft run outs are within acceptable values.
•	•	•	•	•				Rotating part rubbing on stationary part internally.	Check for signs of this and consult Flowserve, if necessary.
•	•	•	•	•				Bearings worn.	Replace bearings.
					•	•	•	Wearing ring surfaces worn.	Touch up or replace worn wearing rings.
			•	•			•	Impellers damaged or eroded.	Replace impellers and check for reason.
				•				Mechanical seal improperly installed.	Check alignment of faces or damaged parts and assembly method used.
				•				Incorrect type of mechanical seal for operating conditions.	Consult Flowserve.
•	•		•	•	•			Shaft running off centre because of worn bearings or misalignment.	Check misalignment and correct if necessary. If alignment is satisfactory check bearings for excessive wear.
			•					Impeller out of balance resulting in vibration.	Check and consult Flowserve.

FAULT SYMPTOM									
Motor protection triggered									
↓	Pump does not start								
↓	Motor overheats								
↓	Unit runs but does not pump								
↓	Unit vibrates or is noisy								
↓	Motor loses filling liquid								
↓	Pump requires excessive power								
↓	Pump does not draw in water at start								
↓	Insufficient pressure developed								
↓	Insufficient capacity developed								
								PROBABLE CAUSES	POSSIBLE REMEDIES
A. System problems									
●				●	●			Abrasive solids in liquid pumped.	Check and consult Flowserve.
●	●	●	●	●	●			Internal misalignment due to improper repairs causing impeller to rub.	Check method of assembly, possible damage or state of cleanliness during assembly.
●	●	●		●				Excessive thrust caused by a mechanical failure inside the pump.	Check wear condition of impeller, its clearances and liquid passages.
●	●			●	●			Improper installation of bearings.	Check method of assembly, possible damage or state of cleanliness during assembly and type of bearing used.
●	●			●	●			Damaged bearings due to contamination.	Check contamination source and replace damaged bearings.
●					●		●	Slide valve not fully open.	Open slide valve.
●			●		●		●	Pressure pipe clogged. Foreign body in the pipe line.	Clean pipe work.
●	●	●			●		●	Pump blocked by impurities inside the pump.	Disassemble pump section and clean.
●	●	●	●	●	●			Pump or motor sluggish.	Check smooth running of motor/pump.
●			●				●	Well filter clogged up.	Remove unit and regenerate well.
	●		●					Coupling between pump and motor faulty.	Remove unit and repair.
●			●	●			●	Suction strainer clogged up.	Remove unit and clean suction strainer.
C. Electrical problems									
			●	●			●	Wrong direction of rotation of motor.	Reverse two phases at motor terminal box.
●	●							Motor circuit breaker incorrectly adjusted.	Readjust motor circuit breaker according to data card or rating plate.
●		●	●	●	●		●	Motor running too slow. Under voltage or wrong frequency.	Check if system voltage and frequency agree with data sheet.
●	●	●					●	Phase failure.	Examine power cable for damage. Check fuses.
●	●	●					●	Blown fuses.	Replace fuses.
●	●						●	Damaged power cables.	Replace power cables.

10 CERTIFICATION

Certificates determined from the Contract requirements are provided with these Instructions where applicable. Examples are certificates for CE marking, ATEX marking etc. If required, copies of other certificates sent separately to the Purchaser should be obtained from the Purchaser for retention with these User Instructions.

Notes:

